

# COLLIMATION UPGRADES FOR HL-LHC

S. Redaelli, A. Bertarelli, R. Bruce, I. Efthymiopoulos, A. Lechner, J. Uythoven  
CERN, Geneva, Switzerland

## Abstract

The upgrade of the LHC collimation system is essential to handle the challenging parameters foreseen for the HL-LHC that aims at colliding beams of up to 700 MJ. Depending of the performance limitations of the LHC Run II at higher energy, we are preparing for a possible staged implementation of collimation upgrades starting already in the LHC long shutdown 2. In this paper, the main collimation upgrade studies are presented, recalling motivations and improved performance goals. The time line for collimation upgrades, synchronized with the LHC long shutdown planning, is discussed. Relevant machine protection aspects, including injection protection device upgrades in the LHC ring, are also discussed.

## INTRODUCTION

The challenges of the High-Luminosity (HL) upgrade of the Large Hadron Collider (LHC) require improving various accelerator systems in order to handle higher stored energies up to about 700 MJ, smaller beam emittances down to  $2.5 \mu\text{m}$  in collision and larger peak luminosities of  $5 \times 10^{34} \text{cm}^{-2} \text{s}^{-1}$  [1]. These challenging beam parameters, necessary to achieve the integrated luminosity goal of  $3000 \text{fb}^{-1}$ , poses concerns for the beam collimation. The present system [2] was designed for 360 MJ stored beam energies and for beams with reduced damage potential. It is therefore important to plan adequate upgrades of the collimation system to ensure the success of HL-LHC.

Larger stored energies require better beam cleaning as well as an improvement of the collimator design, addressing aspects related to machine protection (MP). The single-bunch intensity is almost doubled compared to the design value of  $1.15 \times 10^{11}$  protons and this poses concerns about beam stability from collimation impedance, as the collimator contribution dominates the LHC impedance budget at top energy. Last but not least, the update of the interaction region (IR) layout imposes a re-design of the collimation layouts, both in terms of cleaning and protection from incoming beams and collimation of physics debris.

The present upgrade baseline for collimation includes dispersion suppressor collimation in different insertions, achieved thanks to the new high-field 11 T dipoles, upgrade of the secondary collimators in the cleaning insertions for an improved robustness and a reduced impedance, better shielding of the magnets around the experiments and more efficient physics debris cleaning. New IR requirements impose also a re-design of the IR collimation and of the neu-

tral particle absorber (TAN, whose upgraded version is referred to as TAXN), under the responsibility of HL-WP8, and of the injection protection systems in IR2 and IR8 that are studied by WP14. Other collimation upgrades not yet in the baseline include hollow electron lenses to improve beam collimation by providing an active control of beam halos. Other advanced techniques being studied include crystal collimation and new designs such as the jaws with embedded wires and the rotatable jaw concept.

In this paper the various collimator upgrade solutions that are presently being studied for the LHC upgrade are presented. The present upgrade strategy relies on detailed analysis of the Run I operational experience. After a review of upgrades that already took place in LS1, the planned upgrade works are described. The time line for collimation upgrades is also presented, including necessary steps for the required prototyping and beam validation phases. already in the second LHC long shutdown (LS2).

## COLLIMATION ACTIVITIES IN LS1

Important upgrades of the collimation system have taken place already in the LHC long shutdown 1 (LS1). The main collimation activities are listed below (see [3] and references therein).

- The tertiary collimators in all experimental regions (16 devices) and the secondary collimators (2 devices) in the dump region have been replaced with new collimators with integrated beam position monitors (BPM).
- The layout of physics debris collimation has been upgraded around the high-luminosity experiments: 2 TCL collimators per beam have been added in cells 4 and 6 of IR1 and IR5 (8 new collimators).
- One passive absorber per beam in IR3 have been added to reduce doses on the warm quadrupoles in cell 5.
- An improved collimation vacuum layout has been deployed in IR8, where the 2-in-1 vertical collimators (TCTVB) have been replaced with single-beam collimators.

Consolidation activities of the system, such as the replacement of a primary collimator (TCP) in IR7 that showed over-heating during Run I [4] and the improvements of the control systems [5], also took place. The detailed analysis of performance improvements from the dif-

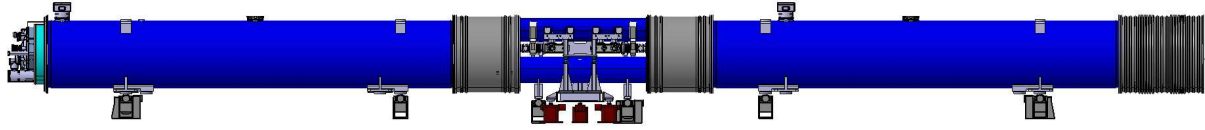

Figure 1: Layout of the unit based on new TCLD collimator and 11 T dipole that replaces a standard LHC dipole to provide local dispersion suppressor cleaning. *Courtesy of D. Duarte Ramos.*

ferent upgrades are reported in various collimation working group meetings [6] and are not reviewed in detail here.

It is noted that the new collimator design with integrated BPM for orbit measurements and faster beam-based alignment is considered as baseline for all future collimators to be produced.

## COLLIMATION UPGRADE SOLUTIONS

### *Dispersion suppressor collimation*

The present collimation system is not optimized to catch efficiently dispersive losses occurring in the dispersion suppressors (DSs) around collimation and experimental insertions. Particles experiencing diffractive interactions with collimator materials or with the opposing beam are lost in the cold DS magnets at the first high dispersion locations. The proposed solution to cure this problem is to install warm collimators close to high dispersion points. This can be achieved by replacing an existing LHC dipole with two higher-field 11 T dipoles, in order to free enough space to install a collimator. The 15 m long unit consisting of 2 new dipoles and 1 collimator is shown in Fig. 1. In IR7, two such units improve the cleaning performance by about a factor 10 according to tracking and energy deposition simulations [7, 8] and reduce losses around the ring for the HL-LHC optics baseline [9]. In IR2 for ion operation, the gain is larger than a factor 50 (as presented in [10]).

Our present strategy for DS collimation follows the recommendations of an international collimation project review organized in May 2013 [10]. According to the present understanding of extrapolations of quench limits and collimation losses to higher energy, and limited by the availability of 11 T dipole units, we plan to equip IR2 with one collimator per beam in LS2 to remove limitations during ion operation. Collimation losses around IR3 and IR7 during Run II are expected to be below quench limits, also thanks to larger margins than foreseen in the superconducting magnets [11]. Clearly, this conclusion will have to be confirmed by operational experience at higher energy.

For the HL-LHC era, two units per beam will definitely be installed around IR7. The need of DS collimation around IR1 and IR5 is expected for ion operation if ATLAS and CMS require the same luminosity as IR2. The optics in this IRs is however different than in IR2. Simulations are ongoing to verify the performance with and without TCLD collimators. Likely, DS collimation will not be needed for proton operation, also thanks to the physics debris collimation solution discussed below. All together, up

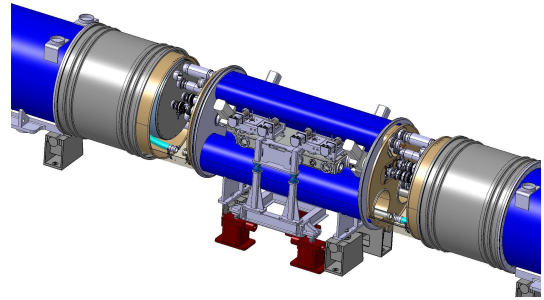

Figure 2: Preliminary layout of the TCLD integration in the by-pass cryostat between two 11 T dipoles. *Courtesy of D. Duarte Ramos.*

to 10 collimators, i.e. 20 11 T dipoles, might be needed for installation in LS3.

The collimator to be installed between 11 T dipoles (TCLD) demands a new design to fit in the tight space between cold magnets. The latest status of integration studies of the cryo by-pass and the TCLD collimator is shown in Fig. 2. The active jaw length of 80 cm initially foreseen is now being reviewed and might be slightly reduced in light of recent updated design of the cold-to-warm transitions (see presentations at the 2014 review of the 11 T dipole study [12]). The TCLD collimator will only have one motor per jaw and is based on conventional materials such as tungsten heavy alloys. We plan to start the construction of a prototype in 2015.

### *Low-impedance and high-robustness collimators*

The present estimates of LHC impedance indicate that the HL-LHC beams will not be stable unless the collimator impedance is significantly reduced [13]. This problem can be satisfactorily addressed by replacing the present secondary collimators made of Carbon-Fibre Composites (CFC) with a low-impedance design, as they are responsible for the largest contribution to the LHC impedance at top energy. Impedance reduction should not be achieved at the expenses of collimator robustness. The present baseline upgrade design is based on Molybdenum-Graphite (MoGR) composite, possibly coated with pure Mo. This is predicted to reduce to about 10 % the individual collimator contributions bringing the total collimation impedance within safe limits [13]. The option without coating might be used for higher-robustness tertiary collimators by gaining a factor up to 1000 compared to the tungsten heavy alloy. This change is beneficial for the  $\beta^*$  reach as it will al-

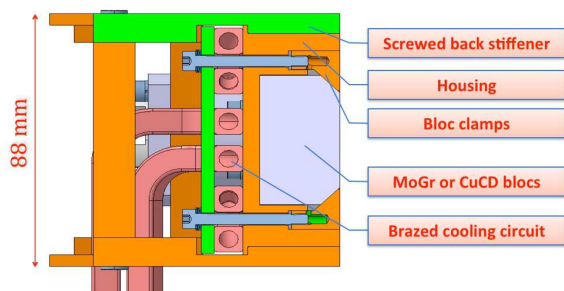

Figure 3: Cross section of the upgraded secondary collimator jaw. Inserts of different materials can be mounted without changing the jaw design. The present baseline relies on MoGR coated with pure Mo. Beam tests are planned at LHC and HiRadMat to confirm the material choice. *Courtesy of F. Carra for the MME team.*

low to reduce further protection margins between dumping system and tertiary collimators [14]. The impact on protection levels from the reduced Z of MoGR is being evaluated.

Production and installation of new secondary collimators must be done for HL-LHC but a partial installation can be envisaged already for LS2, depending on the limitations observed during the LHC Run II and the planned beam parameters for Run III. The jaw design of the new collimator is shown in Fig. 3. Inserts of different materials can be clamped against the cooling plates as shown in figure. This design will be validated by HiRadMat tests as described below. Simulations are ongoing to understand the cleaning performance and the radiation doses in IR7 with the new materials.

Note that the present CFC-based primary and secondary collimators are robust against full train injection failures with the nominal LHC parameters of 288 bunches of  $1.15 \times 10^{11}$  protons with a  $3.5 \mu\text{m}$  emittances. We are presently reviewing the equivalent scenarios for the HL-LHC injection case in order to understand if these collimators will also have to be changed in LS3.

### HiRadMat tests and prototyping for HL-LHC

The beam-based validation of new collimator designs is crucial to ensure the compatibility with the extreme LHC beam conditions. In particular, the verification of the robustness against fast beam losses calls for a qualification with beam. The complexity of the simulations of full-jaw geometry in case of beam impacts, and the absence of detailed information of equations of state for novel materials, make it difficult to predict accurately the collimator response for the relevant failure cases. The HiRadMat facility at CERN provides a unique opportunity to perform such validations in a controlled way [15].

Two collimator tests were already successfully performed at HiRadMat in 2012 [16, 17] where material samples (see also Fig. 4) and a full tertiary collimator were tested against beam impacts equivalent to and beyond the

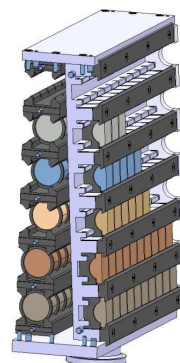

Figure 4: Sample holder housing up to 12 materials as build for the HRM-14 collimator material experiment [16]. *Courtesy of A. Bertarelli.*

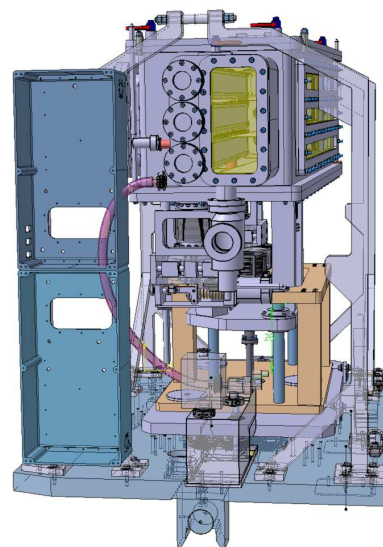

Figure 5: Design of the setup for the full jaw-test at HiRadMat in 2015, HRNT-23 experiment, featuring three jaws in a vertical setup for multiple designs tests. *Courtesy of L. Gentini.*

expected LHC loss cases. Similar tests are now planned for the new designs. In particular, we proposed (1) an integral validation of the robustness of three complete jaws: the present CFC jaw with BPM's and two jaws based made of MoGR and Copper Carbon-Diamond (CuCD); this will be done with the apparatus in Fig. 5 that enables testing 3 jaws in a vertical setup in the same experiment, see 6; (2) the characterization of new material composites and the final grades foreseen for the LHC. Details of these collimation experiments were presented at a recent HiRadMat scientific board meeting [18].

The immediate goals these tests is to enable the finalization of the design of a low-impedance, high-robustness secondary collimator prototype that we would like to install in the LHC during the 2015 Christmas. Collimator slots and cabling have been prepared in LS1 for a quick installation. The needs of MD time to validate this new design are also



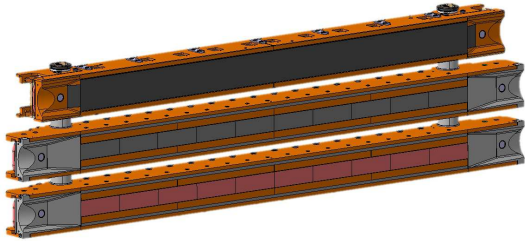

Figure 6: Present baseline for the full-jaw test at HiRadMat foresees to test a CFC jaw with integrated BPMs (top), a MoGR-base jaw (middle) and a CuCD jaw (bottom). *Courtesy of L. Gentini.*

discussed in [19].

### *Hollow e-lenses for active halo control*

Even if the present assumptions on quench limits at 7 TeV were confirmed and betatron losses were below, controlling operational beam loads on the collimation system would remain of paramount importance. For a perfect Gaussian transverse profiles, at HL-LHC beams some 2 MJ are found above  $3\sigma$ . Tail measurements performed so far with LHC beams [20, 21] actually indicate that tails might be significantly over populated, as also confirmed by the analysis of operational beam losses in 2012 [22].

A means to mitigate the problems of losses during standard operation, which already during Run I affected significantly the operation efficiency [23], is to actively control the beam halo diffusion and the tail population. This would mitigate transient loss spikes, e.g. from fast orbit jitters, and ease MP aspects of the operation of crab-cavities when fast failures become more critical in presence of overpopulated tails. Our baseline proposal for HL-LHC is to use hollow electron lenses for this purpose. Following a detailed conceptual design of LHC e-lenses [24], a preliminary design of a device for the LHC, which could be installed in point 4, was produced, see Fig. 7. If the present loss assumptions are confirmed, HL-LHC might need 1 electron lens per beam. In case of severe problems with losses, one could envisage a deployment already in LS2. Otherwise, the installation can be planned for LS3. We are presently evaluating the possibility to prototype this technique with LHC beams by installing one device in LS2.

Alternative methods of halo excitation are also being studied with higher priority, see for example recent discussion [25] and the MD plans for 2015. We expect that until 2016 enough operational experience should be accumulated to decide on the optimum strategy for active halo control at the LHC.

### *Crystal collimation studies*

Crystal collimation is considered as a means to improve collimation cleaning by exploiting the coherent deflection of large-amplitude halo particles through the usage of high-purity bent crystals. The usage of less collimators than for

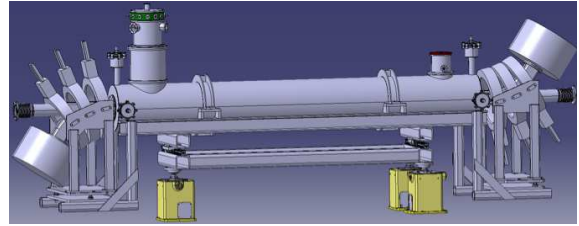

Figure 7: Present design of the LHC hollow e-lens for an integration in P4. *Courtesy of D. Perini.*

the present system, achievable thanks to larger deflection angles that ideally require one single absorber instead of several secondary collimators, might also mitigate the collimation impedance issue. A test setup for crystal collimation studies has been installed in the LHC point 7 for prototyping beam tests with LHC beam conditions, see [26] and references therein. The scope of this first implementation in the LHC is to assess if improvements of collimation cleaning with respect to the present system are possible. This will be done with safe beam intensities only. If crystal collimation is proved successful, confirming at the LHC what has been concluded from SPS beam tests [26], this technique could be considered as an alternative to the DS collimation based on the 11 T dipoles. Note that crystals cannot be used to collimate the physics debris products around experiments because out-scattered protons are still within the main beam due to the small dispersion function in the matching sections.

### *Other ongoing studies and tests*

Present works within the collimation project also address new advanced collimator designs for various purposes. Figure 8 shows, for example, the cross section of a jaw with an integrated wire for long-range beam-beam compensation (LRBBC) studies. Four collimators based on this design will be produced in 2015 and installed in IR1 and/or IR5 in the 2015-16 LHC shutdown, replacing existing collimators in these insertions. The wire embedded in the tungsten blocks of the jaws can be powered up to about 300 A. An MD program is foreseen [19] to benchmark the simulation tools that indicate that such a technique can be used to compensate the effect of the long-range interactions with the opposite beam. From the collimation project side, work is ongoing to demonstrate that the proposed design can replace without loss of performance the existing collimators, see for example [27]: collimators with wires shall replace devices that are needed for the LHC high-intensity operation so changes must be transparent. For the moment, no show-stoppers have been found in the proposed design.

In Dec. 2013, CERN received from SLAC a full-scale prototype of the rotatable collimator [28] that is based on a “consumable collimator jaw” concept. Two cylindrical jaws with 20 flat facets can be rotated in case of jaw damage from beam losses, offering a new collimating surface without need to replace the collimator as it would be re-

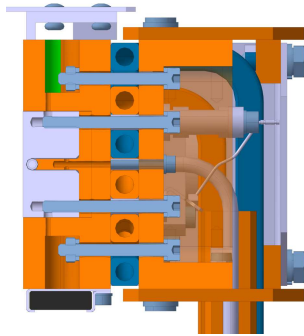

Figure 8: Cross-section of a tungsten-based collimator jaw integrating a wire for long-range beam-beam compensation (LRBBC) studies. Four collimators based on this design will be produced in 2015 and installed in the LHC, replacing existing TCT and TCL collimators, to test the LRBBC schemes in IR1 and IR5. *Courtesy of F.Carra.*

quired for the standard flat-jaw design. The validation of this design without beam has been completed. We plan to test this device in the SPS in 2015 to demonstrate that this design is suitable for operation with circulating beams. It is then planned to test it in the HiRadMat facility (see [18]) in order to demonstrate that the delicate rotation mechanisms continue working as designed after severe beam impacts that damage a facet.

## COLLIMATION IN THE INTERACTION REGIONS

The ongoing collimation layout studies in the different IRs have recently been discussed at the 4<sup>th</sup> Annual HiLumi Meeting [29]. In particular, recent results on collimation layout studies are available in [30]. The present layouts in IR1/5 is shown in Fig. 9 [31].

### *Incoming beam collimation*

The main roles of the incoming beam collimation are: (1) keeping all heat deposition into magnets well below their quench limits in standard operation; (2) protecting the relevant aperture restrictions in case of fast beam failures; (3) optimising the halo-driven background to experiments. For the present LHC layout, these roles are provided satisfactorily by a pair of tertiary collimators located in cell 4, at positions at nearly zero betatron phase difference upstream from the triplet magnets (i.e. located between the D2 and the TAN). This collimator will be maintained for HL-LHC at the same functional position, i.e. at a shifted longitudinal position compared to the present LHC, in order to be compatible with the overall layout changes of the magnetic elements. For the HL-LHC, standard aperture calculations show that potentially critical aperture bottlenecks could be introduced upstream of the triplet. Therefore, we foresee to install a additional pair of horizontal and vertical tertiary collimators in cell 5 in front of Q5. Detailed studies are ongoing to estimate the performance reach of the proposed

layouts in case of standard operational losses and abnormal losses in case of failures [30].

### *Outgoing beam collimation*

Collimation of the outgoing beams at the high-luminosity experiments is designed to keep the heat deposition into superconducting magnets of matching sections and of dispersion suppressors safely below quench limits, protecting them from the products of physics debris. Concentrating losses on the collimators also reduces the effect of total radiation doses to critical components.

The baseline layout for HL-LHC, inherited from the present LHC, is based on 3 horizontal physics debris absorbers placed in cells 4, 5 and 6 (3 movable collimators per beam per side of IR1 and IR5). The HL-LHC challenges require in addition up to 4 fixed masks on the IP-side of D2, Q4, Q5 and Q6. As can be seen from Fig. 9, the TCLs in cells 4 and 5 have been shifted longitudinally in the HL-LHC layout as a consequence of the general layout changes. We are presently working on the detailed design of the new collimators that might have to be changed compared to the present one, in particular in the region between the D2 and the TAN, in order to address some integration issues revealed by the first implementation in the present optics version and to simplify the design of the new TAN for HL-LHC (see below).

### *Injection protection in IR2/IR8*

The injection protection system protects the LHC elements in case of injection failures and specifically failures in time or amplitude of the injection kickers MKI. A schematic view of the key injection elements is shown in Fig. 10. The protection system consists of several absorbers which need to be upgraded following the HL-LHC requirements. The upgrade of the LHC injection absorbers is part of the HL work package 14 [32]. As the main changes in the injector chain, as part of the LIU project, are taking place in LS2, it is proposed to upgrade the LHC injection protection systems following the same timeline.

The main injection absorber taking most of the beam load in case of an MKI failure is the two-sided collimator TDI. It now consists of a single tank per IP and will be replaced by three individual, shorter modules called TDIS's. The jaw materials will need to be replaced. However, for the small BCMS beams under grazing impact, the survival of even the new TDIS absorber materials is not guaranteed [33]. The protection of the D1 will need to be achieved by either a reduction of the transverse aperture of the TCDD mask or a displacement of the TCDD closer to the D1. An alternative presently being studied is to install a mask directly around the beam pipe inside the D1 cryostat [34]. Simulations show that only little beam is to impact on the auxiliary collimators TCLIA and TCLIAB. However, the TCLIA in Point 2 will most likely need to be replaced because of aperture requirements of the ALICE ZDC.

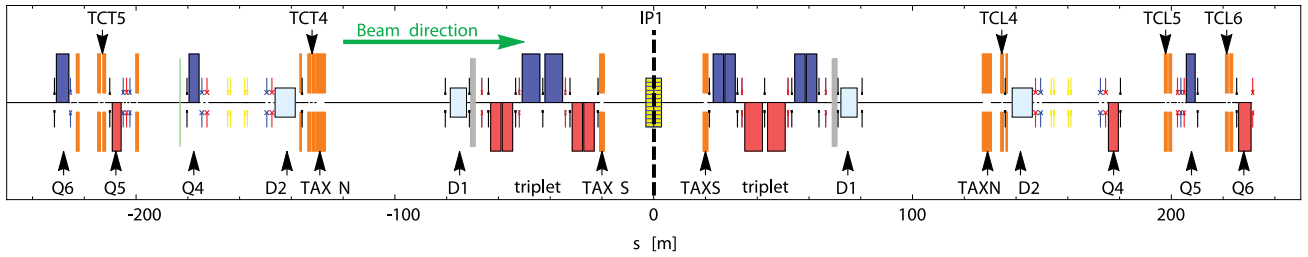

Figure 9: Collimation layout for incoming and outgoing beams in IR1. The IR5 layout is equivalent.

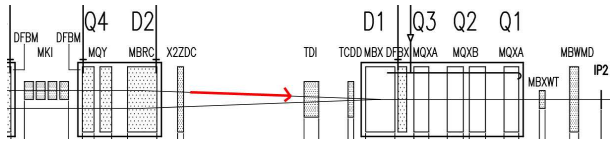

Figure 10: Schematic view of the LHC Point 2 showing the B1 injection region, the injection kickers MKI and absorbers TDI and TCDD. The auxiliary absorbers TCLIA and TCLIB are at the other side of the IP.

The spare TDI absorbers for Run II are equipped with interferometric measurement of the collimator gap. This new gap measurement is to be used as a redundant interlock by the Beam Energy Tracking System (BETS) [35]. In addition, the hBN absorber blocks will be coated with a few microns of copper to reduce the resistive heating. Vacuum and functional tests of the spares are presently ongoing. The plan is to install the spare TDIs in Point 2 and Point 8 during the short 2015/2016 shutdown. If the operation with beam of the interferometric gap measurement is successful, it will be applied for the series TDIs to be installed in LS2.

### TAXN for HL-LHC

New beam neutral absorbers (TAXN) will be installed for HL-LHC operation around the high-luminosity experiments at IP1 and IP5. The new TAXN will follow the same design principles as the existing ones for LHC, however upgraded to meet the increased energy deposition and resulting radiation. The TAXN contains the transition from a single to twin vacuum pipes and is designed primarily to absorb the flux of forward high-energy neutral particles coming out from the interaction region. The aperture of the vacuum pipes will be designed to allow sufficient clearance for all beam optics. With respect to the existing TAN, the TAXN is moved by approximately 4m towards the IP following layouts changes foresee on HL-LHC [1].

Although in the present HL baseline scenario the beam optics for the high-luminosity areas is based on the crab cavities with the so called “round beam optics”, alternative optics configurations with “flat optics”, i.e. with unequal  $\beta^*$  values in the horizontal and vertical planes at the IP, are considered. The requirements for the TAXN aperture design to cope with round and flat options are quite distinct. For the round optics a larger crossing angle is

envisaged that requires larger aperture, while for the flat optics smaller crossing angles pose more challenges in the protection of downstream elements. The present baseline foresees that (1) The TAXN will be designed with a fixed aperture optimized to provide the necessary clearance and maximum protection for the neutral particles. (2) A special design of the TCL collimator in cell 4 will be produced to provide the needed protection to the D2 bend and downstream quadrupoles. We are presently considering the possibility to enlarge transversally the jaw width to make this collimator more efficient [36].

The exact layout configuration and arrangement of the TAXN and the TCL collimator will be defined taking into account all installed materials and collimators in the region. Recent studies using a tungsten for the TAXN instead of copper showed that adequate efficiency could be maintained with a reduction in length that alleviates some layout issues [36]. In terms of schedule, the TAXN design needs to be finalized by end of 2017, which leaves sufficient time to perform all the optimization studies and optimize the designs and energy deposition to the magnets.

## CONCLUSIONS

Upgrading the LHC collimation is crucial for the HL-LHC project. The ongoing studies of collimation solutions that address potential limitations to the present system have been described. A solid upgrade baseline has been established based on in-depth analyses of various aspects of the Run I operational experience. On the other hand, a crucial milestone for collimation will be the confirmation of present assumptions on the Run II operation at higher energies. This will solve present uncertainties on cleaning performance, quench limits, beam losses and collimation impedance etc. The upgrade strategy will be updated and re-tuned, if needed, once sufficient operational experience has been accumulated, i.e. not before the second half of 2015. At the same time we expect also to have at hand the results of important prototyping tests without and with beam, e.g. on new collimator designs and materials (both for the cleaning system and for the protection devices). We believe that we are on a good track to deploy important collimation upgrades starting already in LS2, if required, and that all the potential issues are being addressed.

## ACKNOWLEDGMENTS

This contribution was prepared on behalf of the members of the collimation team as well as of the WP8 and WP14 teams. They are kindly acknowledged for their contributions to this work.

## REFERENCES

- [1] <http://hilumilhc.web.cern.ch/>
- [2] R. Assmann *et al.*, “Collimators and beam absorbers for cleaning and machine protection,” LHC Project Workshop Chamonix XIV, pages 261-267 (2005).
- [3] <http://lhc-collimation-project.web.cern.ch/lhc-collimation-project/LS1/default.php>
- [4] B. Salvachua *et al.*, “Collimation system post-LS1: status and commissioning,” in the proceedings of Evian 2014.
- [5] <https://indico.cern.ch/event/304154/>
- [6] <http://www.cern.ch/lhc-collimation>
- [7] R. Bruce *et al.*, “Cleaning performance with 11 T dipoles and local dispersion suppressor collimation at the LHC,” in the proceedings of IPAC2014.
- [8] A. Lechner *et al.*, “Power deposition in LHC magnets with and without dispersion suppressor collimators downstream of the betatron cleaning insertion,” in the proceedings of IPAC2014.
- [9] A. Marsili *et al.*, “Collimation cleaning for HL-LHC optics scenarios with error models,” in the proceedings of IPAC2014.
- [10] <https://indico.cern.ch/event/251588/>
- [11] B. Auchmann *et al.*, “BLM threshold strategy versus UFOs and quenches,” in these proceedings.
- [12] <https://indico.cern.ch/event/354499>
- [13] E. Métral *et al.*, “Machine settings and operational scenario from stability considerations for HL-LHC,” presentation at the 4<sup>th</sup> Annual Meeting of HL-LHC. Slides available at [this link](#).
- [14] R. Bruce *et al.*, “Baseline machine parameters and Configuration for 2015,” in these proceedings.
- [15] I. Efthymiopoulos *et al.*, “HiRadMat: a new irradiation facility for material testing at CERN,” in the proceedings of IPAC2011.
- [16] A. Bertarelli *et al.*, “First results of an experiment on advanced collimator materials at CERN HiRadMat facility,” CERN-ACC-2013-0268.
- [17] M. Cauchi *et al.*, “High energy beam impact tests on a LHC tertiary collimator at the CERN high-radiation to materials facility,” *Phys. Rev. ST Accel. Beams* **17**, 021004.
- [18] <http://indico.cern.ch/event/303890/>
- [19] G. Arduini, “Down selection criteria and MDs prior to LS3,” in these proceedings.
- [20] G. Valentino *et al.*, “Beam diffusion measurements using collimator scans in the LHC,” *Phys. Rev. ST Accel. Beams* **16**, 021003
- [21] F. Burkart *et al.*, “Experience with high-intensity beam scraping and tail populations at the Large Hadron Collider,” in the proceedings of IPAC2013.
- [22] S. Redaelli *et al.*, “Experience with beam scraping and tail population at the Large Hadron Collider,” in the proceedings of IPAC2013.
- [23] B. Salvachua *et al.*, “LHC collimation cleaning and operation outlook,” *Evian* 2012.
- [24] G. Stancari (FNAL) *et al.*, “Conceptual design of hollow electron lenses for beam halo control in the Large Hadron Collider,” ATS Report CERN-ACC-2014-0248.
- [25] Minutes of the 197<sup>th</sup> LHC Machine Committee held on 3<sup>rd</sup> Dec. 2014, [available at this link](#).
- [26] Presentation by W. Scandale *et al.*, and minutes of the 173<sup>rd</sup> LHC Machine Committee held on 5<sup>th</sup> Feb. 2014, [available at this link](#).
- [27] Presentation at the 181<sup>st</sup> Collimation Working Group meeting of 18<sup>th</sup> Oct. 2014, [available at this link](#).
- [28] <http://lhc-collimation-project.web.cern.ch/lhc-collimation-project/slac.collimator.php>
- [29] <https://indico.cern.ch/event/326148>
- [30] <https://cds.cern.ch/record/1972595/files/CERN-ACC-2014-0293.pdf>
- [31] R. Bruce *et al.*, “Collimation status and layout for IR1 and IR5,” presentation at the 4<sup>th</sup> Annual Meeting of HL-LHC. Slides available at [this link](#).
- [32] J. Uythoven *et al.*, “HL-WP14 overview,” presentation at the HL-LHC Annual Meeting at KEK, 17-21 November 2014. Available at [this link](#).
- [33] V. Kain *et al.*, “Concerns with low emittance beams operation,” in these proceedings.
- [34] A. Lechner *et al.*, “Protection of superconducting elements in the case of injection failures,” presentation at the HL-LHC Annual Meeting at KEK, 17-21 November 2014. Available at [this link](#).
- [35] N. Magnin, “LBDS: status and plans,” in the proceedings of Evian 2014.
- [36] F. Cerutti *et al.*, presentation at the HL-LHC Annual Meeting at KEK, 17-21 November 2014. Available at [this link](#).