

Grant Agreement No: 284404

HILUMI LHC

FP7 High Luminosity Large Hadron Collider Design Study
Seventh Framework Programme, Capacities Specific Programme, Research Infrastructures,
Collaborative Project, Design Study

DELIVERABLE REPORT

BEAM HALO SIMULATIONS

DELIVERABLE: D5.3

Document identifier:	HILUMILHC-Del-D5-3.doc
Due date of deliverable:	End of Month 12 (Nov. 2012)
Report release date:	01/05/2013
Work package:	WP5
Lead beneficiary:	CERN
Document status:	Final

Abstract:

Beam halo simulations: simulate and compare beam losses in IR1 and IR5 for various scenarios of halo and upgrade changes. Verify that an upgrade scenario has acceptable loss characteristics. For the verified scenarios provide inputs to energy deposition and other studies.

Copyright notice:

Copyright © HiLumi LHC Consortium, 2012.

For more information on HiLumi LHC, its partners and contributors please see www.cern.ch/HiLumiLHC

The HiLumi LHC Design Study is included in the High Luminosity LHC project and is partly funded by the European Commission within the Framework Programme 7 Capacities Specific Programme, Grant Agreement 284404. HiLumi LHC began in November 2011 and will run for 4 years.

The information herein only reflects the views of its authors and not those of the European Commission and no warranty expressed or implied is made with regard to such information or its use.

Delivery Slip

	Name	Partner	Date
Authored by	R. Bruce, A. Lechner, S. Redaelli	[Short name]	dd/mm/yy
Edited by	I. Surname	[Short name]	dd/mm/yy
Reviewed by	I. Surname [Task coordinator]	[Short name]	dd/mm/yy
	I. Surname [WP coordinator]	[Short name]	
	I. Surname [Scientific coordinator]	[Short name]	
Approved by	Steering Committee		dd/mm/yy

TABLE OF CONTENTS

1. INTRODUCTION	4
2. BEAM HALO LOSSES WITH AND WITHOUT DS COLLIMATORS.....	6
2.1. LOSSES AROUND THE RING WITH $\beta^*=15$ CM	6
2.2. UPDATED LAYOUT BASED ON 11 T DIPOLES.....	7
2.3. COLLIMATION CLEANING FOR STANDARD OPTICS.....	7
2.4. COLLIMATION CLEANING FOR ATS OPTICS WITH DS COLLIMATORS	9
3. ENERGY DEPOSITION FROM PHYSICS DEBRIS IN IR1 AND IR5.....	10
4. ENERGY DEPOSITION STUDIES FOR ION COLLISION LOSSES IN IR2 FOR ALICE UPGRADE CASES	12
4.1. INTRODUCTION.....	12
4.2. IR2 DISPERSION SUPPRESSOR LAYOUT AND FLUKA GEOMETRY.....	14
4.3. ENERGY DEPOSITION RESULTS FOR ION OPERATION (PRELIMINARY).....	15
5. FUTURE PLANS / CONCLUSION / RELATION TO HL-LHC WORK	17
REFERENCES	18
ANNEX: GLOSSARY.....	19

Guidance notes (to be deleted from deliverable itself)

Deliverable Reports are committed contractual outputs of the project and must be sent to the EC according to the timetable indicated in Annex 1 of the Grant Agreement.

* N.B. Each Deliverable has to be associated with a written report, regardless of its nature, e.g. web-site, device, specification, etc.

Workflow (to be deleted from deliverable itself)

Lead Beneficiaries assemble & produce deliverable report. (due date of Annex 1 + 10 days)

Task and WP Coordinators review and validate deliverable within 20 days of receiving it.

Scientific Coordinator sends deliverable to the Steering Committee for review and approval, then the report is deemed “final” and is submitted to the EC.

Executive summary

The work on collimation upgrade studies has proceeded well in the first 18 month of the HiLumi-WP5 activities. Significant efforts were devoted to the preparation of an important external review of the collimation project that took place at the end of May 2013 and set the scene for the basic timeline and strategy for future system upgrades also affecting the HL-LHC choices. Indeed, the review addressed the definition of a baseline upgrade strategy of the dispersion suppressor (DS) collimation that is a critical topic for HL-LHC. It was decided that a final decision could only be taken towards the second half of 2015 after having accumulated enough experience at the LHC at energies close to 7 TeV. The results presented at the review illustrated that focus must be put on IR2 for ion operation and on IR7 for high-intensity proton operation. This result is one of the main outputs of the design study for collimation: this is why IR2 and IR7 have been the focus of HiLumi-WP5 so far.

Contributions from the HiLumi teams were crucial to determine the present baseline that involves possible upgrades of the dispersion suppressors in IR2 and IR7: these IRs represent the most urgent cases where collimation aspects must be addressed. Simulations of performance reach with and without upgrade collimation layouts could be presented by using the simulation models developed in the context of the HiLumi works (as reported in previous deliverable documents). In particular, first simulations of LHC performance with DS collimators in IR2 with 11 T dipoles were achieved. Simulations were also extended to address possible upgrade scenarios in IR7 for high-intensity proton operation (ATS optics with and without DS collimation). The focus on IR1 and IR5 was put on lower priority because these IRs do not represent immediate limitations for proton operation: preliminary simulation results indicate that the solutions put in place now – based on collimation in the matching sections only – could be adequate also for HL-LHC. Further studies on that will continue with high priority.

1. INTRODUCTION

The ATS optics, foreseen to be used in the HiLumi LHC, introduces major changes to the optics in the experimental IRs and the arcs [1]. It is therefore important to verify that the cleaning of beam halo, by which we mean a safe removal of the slow continuous unavoidable losses by collimators during standard operation, is still appropriate with the new optics, and can handle the foreseen higher intensities. In this case we assume that the halo particles first impact on the primary collimators in IR7 and study the leakage out of the betatron collimation system. The simulation setups for collimation studies with ATS were satisfactorily achieved in the first year of the HiLumi-WP5 activity. The preliminary results based on a perfect collimation system and LHC machine indicated potential issues of losses in the arcs where high beta functions and orbit shifts are required by this new scheme. Possible solutions to this problem were addressed by simulations that include possible upgrade layouts with one or two DS collimators in the cold areas around IR7.

A large fraction of the total losses is, however, created in the collisions inside the LHC experiments. These particles and their products, in particular if they have undergone inelastic or single diffractive scattering, are likely to be lost close to the experiments and never reach IR7. Therefore, these losses, which we call physics debris, have to be studied separately in order to make sure that the local protection of the cold magnets downstream of the experiments is sufficient. The studies performed so far indicated that the operation in IR1 and IR5 until LS3 could be compatible with the expected LHC parameters with an upgrade layout proposed for implementation in LS1: this upgrade relies on 2 or 3 TCL collimators installed in

the matching sections of IR1 and IR5 without modifications of the DS. This solution is not adequate for the ion operation, in particular for an upgrade of the ALICE detector in IR2 to achieve peak luminosities up to $7 \times 10^{27} \text{cm}^{-2} \text{s}^{-1}$. The IR2 case is a critical one that might call for actions already before the HL-LHC era.

This report is therefore split in two parts, where the first part concerns the halo cleaning (section 2) and the second part concerns the physics debris in IR1 and 5 (section 3) and in IR2, which is relevant in particular for heavy ions (section 4).

For the halo cleaning, the focus is on losses downstream of the IR7 cleaning insertion, where new loss locations are observed in the ATS optics. Depending on the exact quench limit of the magnets, and the beam lifetime in the future HL-LHC, these new losses might become limiting. Therefore, a considerable effort has been made to understand and mitigate these losses by installing new collimators. This was one of the main topics at the external [collimation review](#), which was held over two days in May 2013.

It is noted that the study of quench limits of LHC magnets is obviously an input of paramount importance for the upgrades of the collimation system. As reported at the collimation review, an impressive effort was done by the collimation teams to improve the understanding of the quench limits. New beam data made available in dedicated quench tests at the LHC (achieved also with contribution from HiLumi-WP5 members) has been used to benchmark the simulations. Inputs of simulations were provided to the magnets experts for updated quench limit simulations. This important work is not reported in detail in this report (see presentations at the collimation review for reference).

2. BEAM HALO LOSSES WITH AND WITHOUT DS COLLIMATORS

Simulation models of the halo cleaning, using the SixTrack code with an additional collimation routine, were successfully setup in task 5.2 and in this report we show how the models were applied to the HL-LHC collimation studies. During the first studies, locations with high losses were discovered in the arcs downstream of IR7. These loss locations, which are not observed with the nominal optics, must therefore be studied in detail, in addition to the halo cleaning in the upgraded IR1/5 that was the original goal of the task. A considerable effort has been put into understanding and mitigating the losses downstream of IR7, by installing new collimators in the dispersion suppressor (DS).

2.1. LOSSES AROUND THE RING WITH $\beta^*=15$ CM

Figure 1 shows the losses, as presented at IPAC 13 [2], from betatron cleaning around the ring as simulated with SixTrack using the ATS optics with $\beta^*=15$ cm and nominal collimator settings (TCP at 6σ , TCS at 7σ and TCTs in IR1 and IR5 at 8.3σ). As can be seen, the main loss locations are, as for the standard optics, on the IR7 collimators, with a leakage out to the dispersion suppressor downstream of IR7 of the order of a few $1e-5$. However, new loss locations of similar height are observed in the downstream arcs. The loss locations are not present in the nominal optics and could become a future limit.

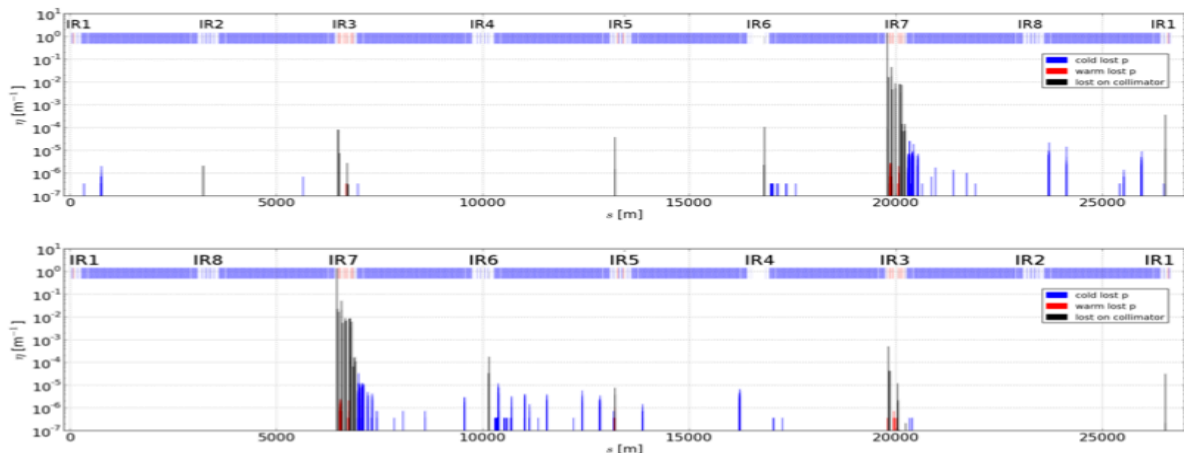

Figure 1: Simulated losses from betatron cleaning in ATS optics in B1 (top) and B2 (bottom) as presented at IPAC 13 [2].

It is, at the time of writing, not clear whether these additional losses will impose future limits on the intensity. With the present knowledge of the quench limit, as extrapolated to 7 TeV from the 2013 proton quench test [3], and with a 0.2h beam lifetime, the intensity is expected to be limited at 1.6 times the foreseen HL-LHC intensity [4]. Although this might seem enough, it should be noted that there are very significant uncertainties on the assumptions that the calculation is based on. Therefore, mitigation methods have to be studied in order to be prepared in case these losses turn out to be limiting.

The leakage to the tertiary collimators (TCTs) in front of ATLAS and CMS is a few $1e-4$ in the highest cases. This is very similar to what is expected in the nominal optics with the same collimator settings, and thus we do not expect any limitation from halo losses in the experimental IRs during standard operation. Instead, the most serious limitation for halo

losses is in the IR7 DS and in the arc. Therefore this is the focus of the rest of this chapter. It is foreseen to address background studies in the future.

2.2. UPDATED LAYOUT BASED ON 11 T DIPOLES

The losses in the IR7 DS and downstream arcs consist of particles that have scattered out of the collimators with large momentum offsets but not large enough betatron amplitudes to hit the downstream collimators. They do not get large transverse offsets until they reach the DS, where the dispersion starts to rise. A possibly very efficient way of intercepting them is thus to install additional collimators in the DS itself, where the dispersion has started to rise. We call these collimators TCLD. The TCLD locations must be upstream enough to intercept the losses, with the important peaks starting in cell 8. At the same time they have to be downstream enough where the dispersion is already important. This constrains the possible locations to places where the available space is presently insufficient for installation.

The preferred solution to create space for a TCLD is therefore to remove one existing dipole magnet and replace it by two shorter magnets with a higher field of 11 T, as shown in Figure 2 [5]. Between the two new magnets, there is enough space for a collimator of about 1m. In order to introduce the DS collimators into the SixTrack simulation setup in a flexible way, a script was implemented to replace in MAD-X any existing dipole, identified by name, by two shorter ones with a collimator in between.

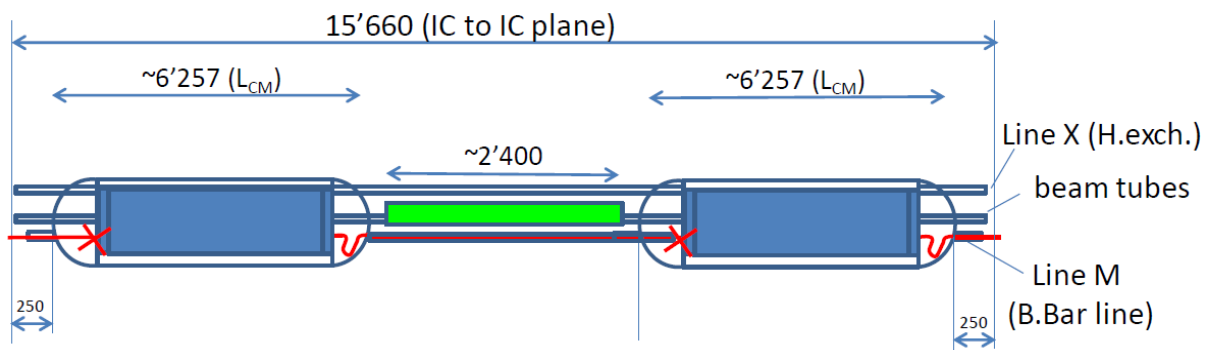

Figure 2: Preferred layout, taken from [5], of the assembly consisting of two shorter dipoles with a collimator in between, that can replace an existing LHC dipole.

Previous schemes were studies that required moving the existing 15 m long dipoles and lattice quadrupoles to make the necessary space for a collimator installation available [REF to collimator review 2011, <https://indico.cern.ch/event/139719>]. The 11 T dipole solution is favoured because it is more transparent for the machine and it can be applied to all LHC insertion regions. This will become the baseline if the Nb₃Sn magnet technology will be available in time for an implementation suitable for the LHC needs [Ref to 2013 coll review].

2.3. COLLIMATION CLEANING FOR STANDARD OPTICS

Several positions were considered of the TCLDs, with the most promising ones being in cells 8 and 10. We therefore focus on these locations. Apart from the future ATS optics, we study also the benefits of the TCLDs in the present nominal optics, as they might help in increasing the LHC performance reach already before the upgrade. To this end, it is important to conceive – if possible - a layout that will be compatible with both layout options (present machine until LS3 as well as HL-LHC beyond LS3) in order to avoid repeating major installation works in different long shutdowns.

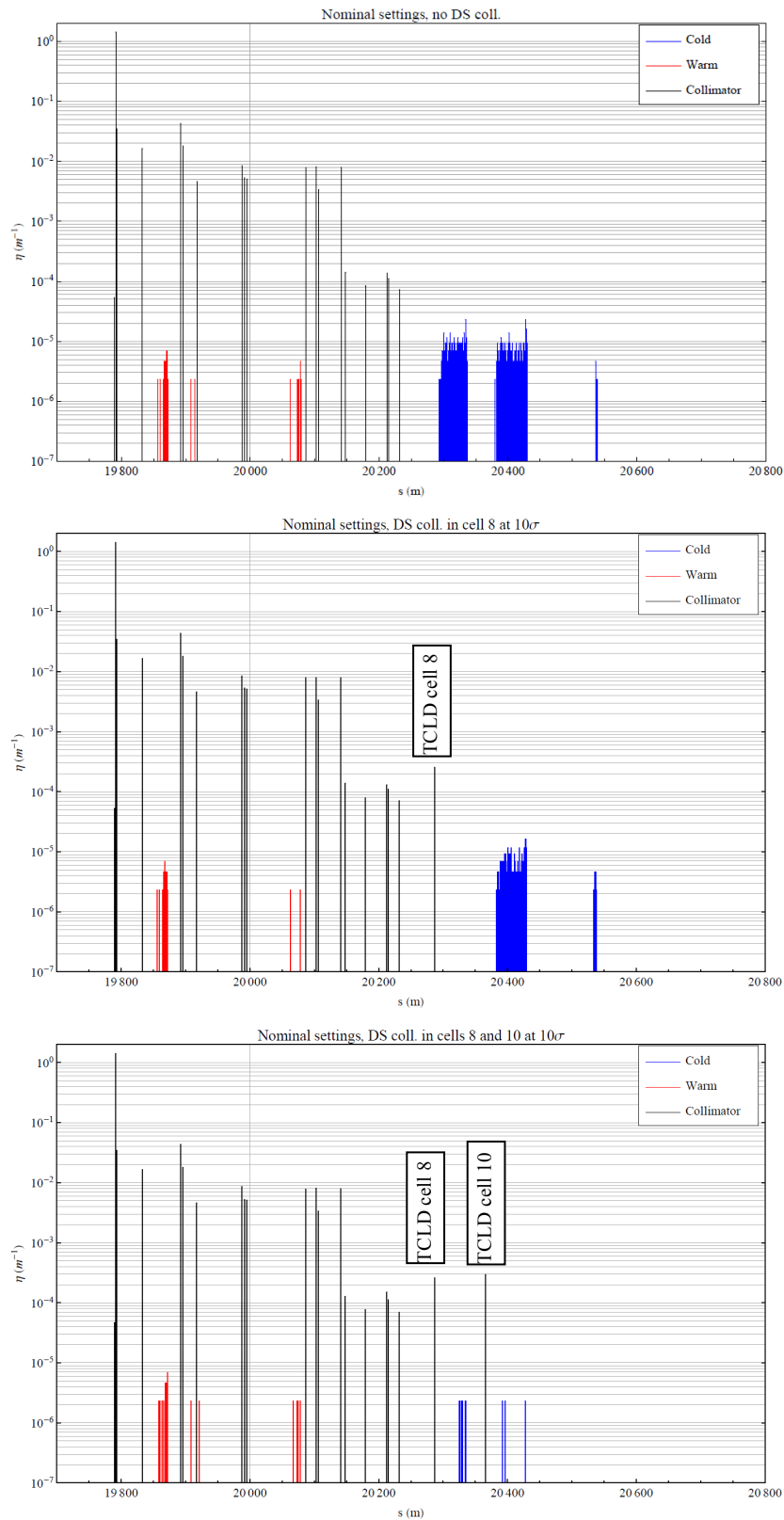

Figure 3: SixTrack simulation of beam-halo losses downstream of IR7, B1, in the nominal optics ($\beta^*=55\text{cm}$) with nominal collimator settings for the case of no additional collimators (top), with one additional TCLD in cell 8 (middle) and with 2 additional TCLDs in cells 8 and 10 (bottom). A setting of 10σ was used for the TCLD.

In Figure 3 the simulated losses in the IR7 DS are shown with 0, 1 or 2 TCLDs. As can be seen, the TCLD in cell 8 intercepts efficiently the first cluster of cold losses starting at $s \approx 20300\text{m}$, while the second cluster at $s \approx 20400\text{m}$ is unaffected. This is due to the fact these losses have smaller momentum offsets, so that the dispersion at the TCLD in cell 8 is not large enough to intercept them.

Instead, the second TCLD in cell 10 is positioned at a place where the dispersion is larger. With two TCLDs installed, practically all simulated losses in the DS are intercepted. However, the TCLD in cell 10 is, evidently, too far downstream to intercept the first loss cluster. Therefore it is clear that both TCLDs are required to suppress the losses at both locations. In terms of settings, the TCLD in cell 10 could be opened to 15σ without significant loss in efficiency, while the losses in the first location start to slowly increase if the TCLD in cell 8 is opened. However, also with a setting of 13σ , gain of more than a factor 3 is found in the peak, and significantly more in the integrated losses.

The simulations show that the installation of two TCLDs in the IR7 DS could significantly improve the cleaning, with more than one order of magnitude gain in losses. This could be important in order to increase the operational flexibility already before the upgrade. Our results are consistent with previous studies [6,7] in which DS collimators were instead installed in spaces in front of the quadrupoles, which was created by moving several magnets [REF coll rev 2011].

2.4. COLLIMATION CLEANING FOR ATS OPTICS WITH DS COLLIMATORS

Similar simulations, with DS collimators installed in cells 8 and 10, have been performed for the ATS optics and the results are presented in [8]. The resulting losses around the LHC are shown in Figure 4. The resulting gain in the IR7 DS is very similar to what was found for the nominal case. However, in addition, the DS collimator in cell 10 efficiently intercepts also particles that otherwise would be lost in other parts of the ring, most notably in the downstream arcs. The two proposed TCLDs are thus sufficient for overcoming the possible performance limit coming from the additional losses appearing around the ring in the ATS optics.

From the results shown in Figure 3 and Figure 4, we draw the conclusions that installation of two TCLDs is a very effective way of increasing the cleaning efficiency in both the nominal and ATS optics. The proposed locations, in cells 8 and 10, work equally well for the nominal and upgrade scenarios.

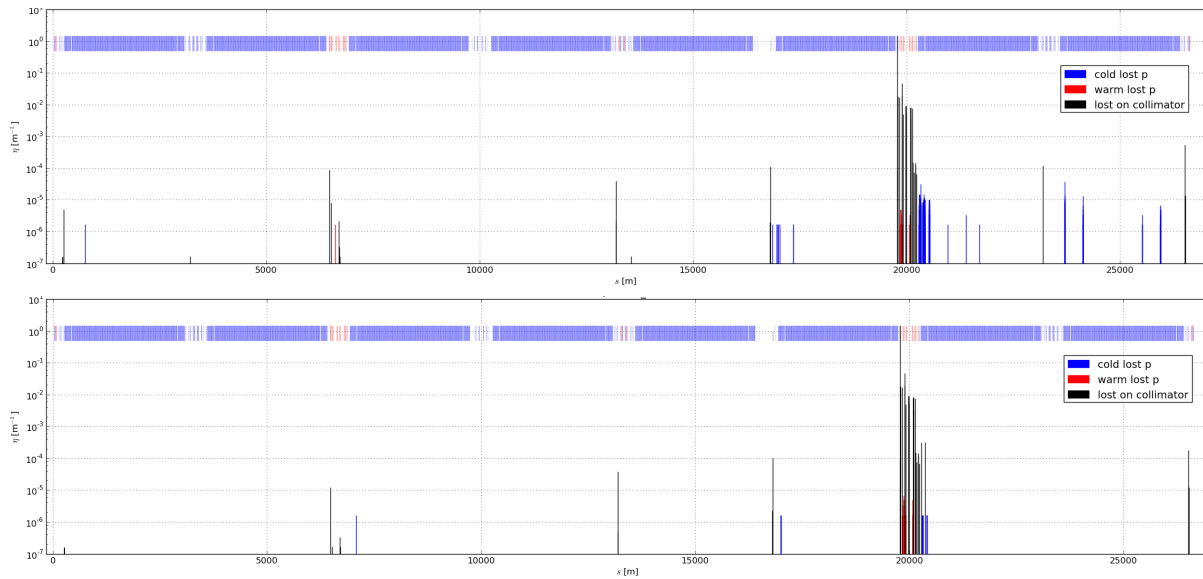

Figure 4: Betatron cleaning losses around the LHC ring, as simulated with SixTrack using ATS optics and $\beta^*=15\text{cm}$, for the case without TCLD collimators (top) and with two TCLDs installed in cells 8 and 10 (bottom). Figure taken from [8].

The results achieved so far are done with perfect machine conditions, i.e. with a perfect collimation system without tilt, gap and jaw flatness errors and without orbit, optics and aperture errors. The models will be extended to include the most relevant errors. It is however noted that the effectiveness of the TCLD collimators in reducing dispersive losses around the ring is expected to be preserved.

3. ENERGY DEPOSITION FROM PHYSICS DEBRIS IN IR1 AND IR5

As a protection measure against proton collision debris from the IPs, the current IR1/IR5 layouts feature one TCL, installed in front of Q5 (TCL-5), which will be complemented by up to two additional TCLs during LS1, one in front of D2/Q4 (TCL-4) and potentially one in front of Q6 (TCL-6) [9]. No further installations of physics debris collimators are currently planned until LS3 and the proposed protection layout could potentially pose a valid option also for HL-LHC operation beyond LS3 (see Deliverable Report 5.2). Clearly, layout modifications for the HL-LHC era will be needed to match the new IR configurations.

As a first step towards the new TCL layout, FLUKA simulations have been carried out to quantify the TCL protection efficiency for nominal operation after LS1. These simulations can be considered as a starting point for future energy deposition calculations tailored to HL-LHC specifications. This section summarizes the first FLUKA results for nominal operation presented by L. Esposito *et al.* [10] at the 2nd Joint HiLumi LHC-LARP Annual Meeting, held in November 2012 in Frascati. The simulations focus on the impact of TCL-4 and TCL-5 on the machine when being operated with a half gap of 10σ , but do not yet include a possible TCL-6. The protection efficiency of the TCL-6, as well as the consequences of more relaxed TCL settings, as potentially required by forward physics experiments [9], are subject of ongoing studies.

The power loads to LSS magnets under study (D2-Q7) are generally higher in IR5 than in IR1 owing to the horizontal crossing scheme in IR5. Hence, results presented in this section exclusively cover IR5. Figures 5 and 6 show the collision debris-induced peak power density

in coils of LSS magnets for different TCL configurations, including the case where no TCLs are present. The results demonstrate that, for a nominal 7 TeV luminosity ($10^{34} \text{ cm}^{-2} \text{ s}^{-1}$), power densities in D2 and Q4 stay well below 1 mW/cm^3 even without TCL protection, suggesting that magnet quenches can be excluded (as already indicated by previous studies [11,12]). Apart from this (and also consistent with earlier findings [11, 12]), the simulations however indicate that a protection is needed for Q5 and Q7. As illustrated in Figure 6, the TCL-4 globally yields a better protection of matching section magnets than the TCL-5. This is also reflected in Figure 7, showing the total power load on LSS magnets and collimators.

The most impacted magnets beyond the Q7 are the dispersion suppressor magnets in cells 8-9 and 11. Contrary to the LSS, the TCL-4 provides less protection than the TCL-5 to magnets in cells 8-9, while the power densities induced in cell 11 show no dependency on the TCL configuration. For illustration, Figure 8 displays the proton loss density and the coil peak power density in cells 8 and 9 in presence of the TCL-4. The results indicate maximum values of 0.1 mW/cm^3 , which is comparable to the maximum values found in LSS magnets in the case that the TCL-4 is present.

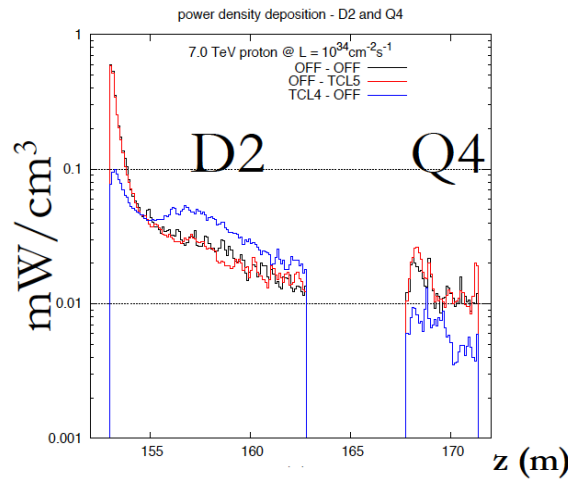

Figure 5 Peak power density in D2 and Q4 coils due to debris from proton collisions in IP5. Results correspond to an instantaneous luminosity of $10^{34} \text{ cm}^{-2} \text{ s}^{-1}$. Figure as presented by L. Esposito et al. [10] at the 2nd Joint HiLumi LHC-LARP Annual Meeting.

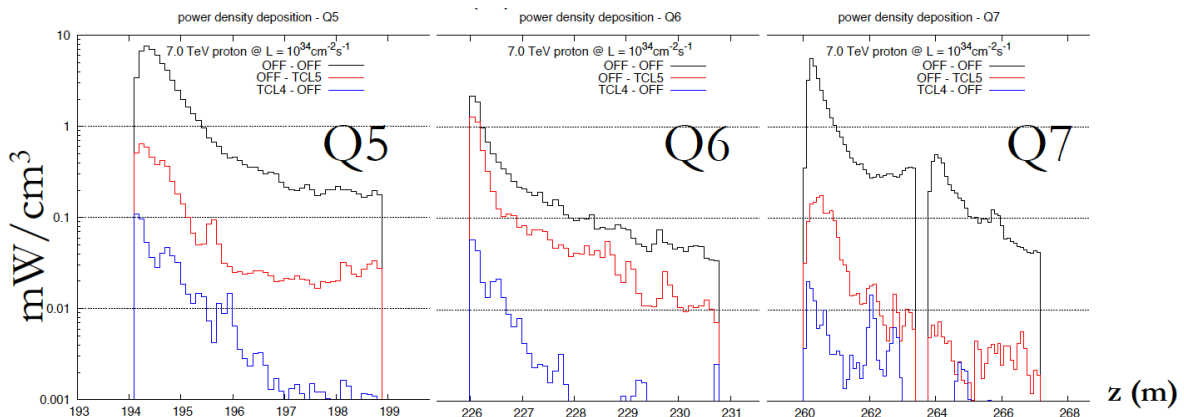

Figure 6: Peak power density in Q5, Q6 and Q7 coils due to debris from proton collisions in IP5. Results correspond to an instantaneous luminosity of $10^{34} \text{ cm}^{-2} \text{ s}^{-1}$. Figure as presented by L. Esposito et al. [10] at the 2nd Joint HiLumi LHC-LARP Annual Meeting.

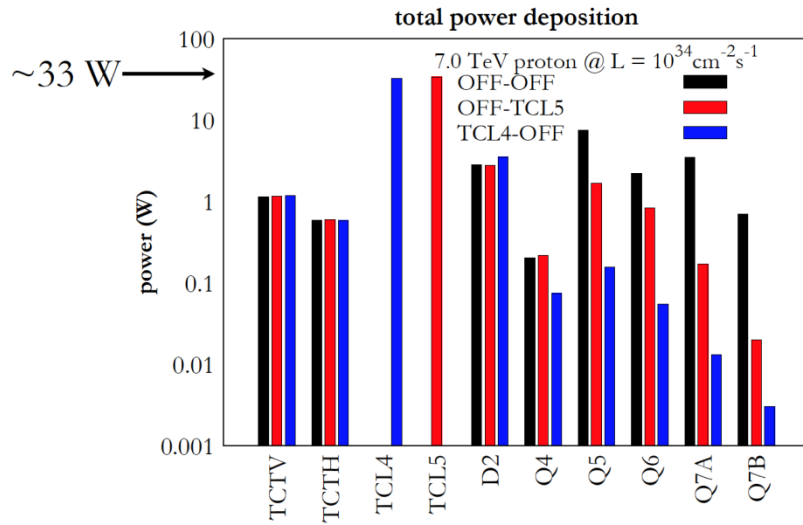

Figure 7: Total power load to TCTs, TCLs and LSS magnets due to proton collision debris from IP5. Results correspond to an instantaneous luminosity of $10^{34} \text{ cm}^{-2} \text{ s}^{-1}$. Figure as presented by L. Esposito et al. [10] at the 2nd Joint HiLumi LHC-LARP Annual Meeting.

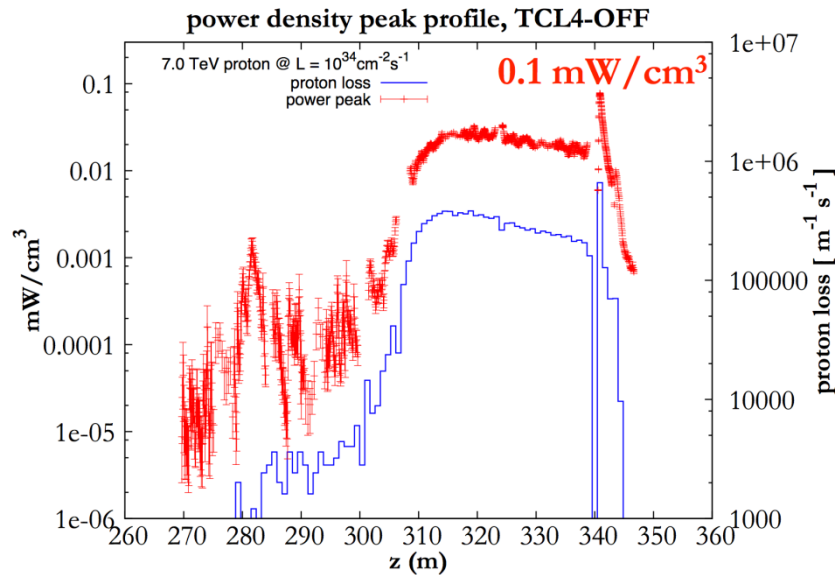

Figure 8 Proton loss density in dispersion suppressor magnets (cells 8 and 9) as well as peak power density in magnet coils in presence of TCL-4. The contribution of the shower from the LSS into cell 8 is not included. Results correspond to an instantaneous luminosity of $10^{34} \text{ cm}^{-2} \text{ s}^{-1}$. Figure as presented by L. Esposito et al. [10] at the 2nd Joint HiLumi LHC-LARP Annual Meeting.

4. ENERGY DEPOSITION STUDIES FOR ION COLLISION LOSSES IN IR2 FOR ALICE UPGRADE CASES

4.1. INTRODUCTION

Collisional losses have to be treated separately for heavy ions, as different physical processes determine the dominating losses [9]. Ultraperipheral electromagnetic interactions, which

change the charge-to-mass ratio of the incoming ions, take place when the impact parameter is larger than the nuclear diameter. The dominating processes are:

- Bound-free pair production (BFPP1): an electron-positron pair is created and the electron is caught in a bound state by one of the ions, thus changing its charge.
- Bound-free pair production (BFPP2): same as BFPP1 but with both ions capturing an electron
- 1-neutron electromagnetic dissociation (EMD1): one of the colliding ions emits a neutron, thus changing mass
- 2-neutron electromagnetic dissociation (EMD2): one of the colliding ions emits two neutron, thus changing mass

A large variety of other electromagnetic dissociation processes is also possible, but with much lower cross sections.

Because of the change in charge-to-mass ratio, ions that have undergone any of the above processes will deviate from the main beam and follow the local dispersion created since the IP. They can then be lost on the aperture if the dispersion is large enough. For the case of Pb^{82+} ions, the dispersive trajectories coming out from the ALICE experiment in nominal optics, are shown in Figure 9. As can be seen, the secondary beams from BFPP1 and BFPP2 are lost locally in the dispersion suppressor, while EMD1 and EMD2 cause losses further downstream. These losses risk to quench the magnets and therefore limit the performance, in particular in view of a possible upgrade of the ALICE detector that might take place before the HL-LHC implementation. It is noted that the present IR2 optics is expected to be maintained with minor modifications for the HL-LHC era and therefore the limitations discussed here are representative of the post-LS3 operation as well.

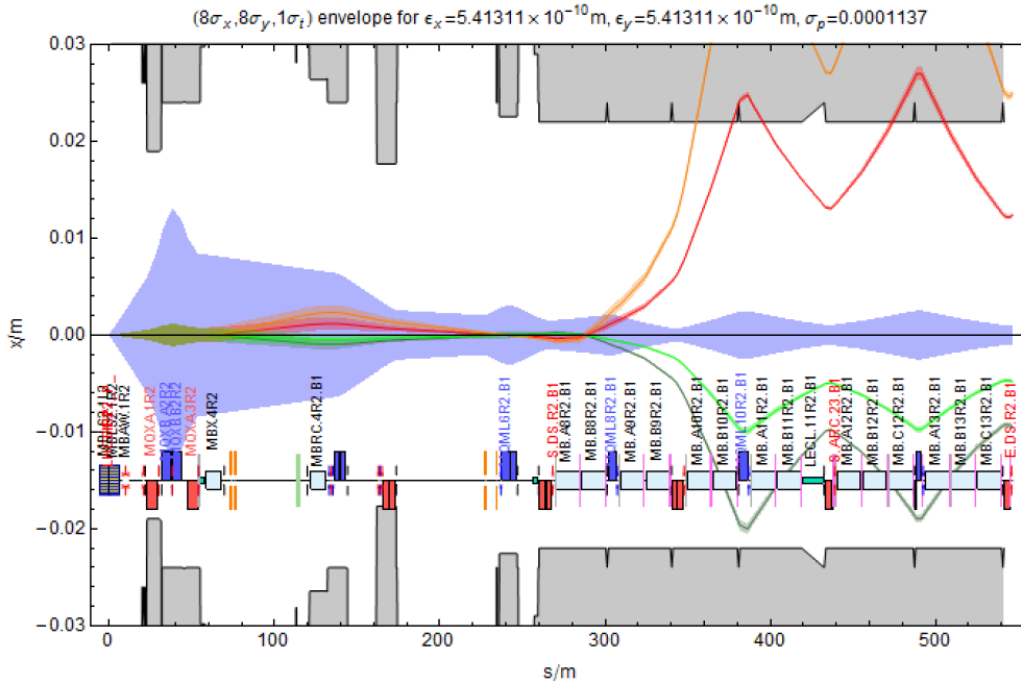

Figure 9: Envelope of the main Pb^{82+} beam (violet) together with the dispersive trajectories of ions undergone BFPP1 (red), BFPP2 (orange), EMD1 (light green) and EMD2 (dark green) coming out of the ALICE experiment in nominal optics. Courtesy of J. Jowett.

In terms of cross sections, BFPP1 is the dominating process for Pb^{82+} at the nominal energy of 2.76 TeV/nucleon with a cross section of 281 b, followed by EMD1 at 96 b and EMD2 at

29 b [9]. The BFPP2 cross section is for this running scenario very small so its contribution can safely be neglected. Earlier studies [9] have shown that BFPP1 might be limiting the nominal Pb82+ luminosity. However, recent findings indicate that the quench limit of the affected magnets is higher than previously estimated [10,11] which would bring the nominal luminosity within reach. However, for a possible upgrade of ALICE, with a 6 times higher luminosity, the BFPP1 losses are still estimated to limit the peak luminosity by a factor 2.

The BFPP1 losses, on which we focus hereafter, could possibly be cured using the same strategy with DS collimators as studied for IR7, i.e. by implementing local collimation in the DS by replacing at appropriate location(s) a standard LHC cryo-dipole with the unit of Fig. 2.

4.2. IR2 DISPERSION SUPPRESSOR LAYOUT AND FLUKA GEOMETRY

In IR2 we need only to install one TCLD per side of the experiment, and thus only replace one dipole with shorter 11T magnets. Otherwise, the proposed layout changes are fully analogous to the one discussed for IR7 in Section 2.

The most suitable dipole to replace for the installation is found to be the MB.A10R2.B1, about 357 m downstream of IP2. A TCLD installed there would not only intercept the most dangerous BFPP1 beam, but also the EMD1 and EMD2 beams. In order to quantify the gain from this installation, a new set of energy deposition simulations have been performed with FLUKA [10] to study the heat load on the affected magnet with and without the TCLD. As a first step, tracking was performed as in [9] to obtain the impact distribution on the TCLD or on the dipole beam screen in case of its absence. A TCLD half opening of 43σ (~ 9.5 mm) was assumed, which is far enough from the main beam to not have any influence on the standard collimation hierarchy, but at the same time provides a large impact parameter of the BFPP1 beam of 2 mm, corresponding to 9σ .

The tracking output was used as a starting point for the FLUKA simulations. Two layouts were studied, one comprising the TCLD and 11T dipoles as a replacement of MB.A10R2, and the second representing the current dispersion suppressor layout, with the MB.B10R2 as the most impacted magnet (estimates of the energy deposition without TCLD have been published previously in [9]). The FLUKA model of the 11T two-in-one dipole, hereafter referred to by its CERN development name MBHDP, closely follows the magnet design elaborated in WP11. The model implementation features all geometrical characteristics essential for energy deposition studies, including an accurate representation of coils, coil wedges, poles, collars, yoke and cold mass shell. A realistic description of the magnetic field has been imported into the FLUKA model database to allow for an accurate particle tracking in coils, collars and yoke. As the design and integration of the TCLD by-pass cryostat has not yet been finalized, an approximate model of the collimator assembly has been adopted in the FLUKA simulations, which reuses elements of the LTC assembly originally developed for a different TCLD integration solution. A 3D-rendering of the MBHDP FLUKA model and the collimator assembly is displayed in Fig. 6.

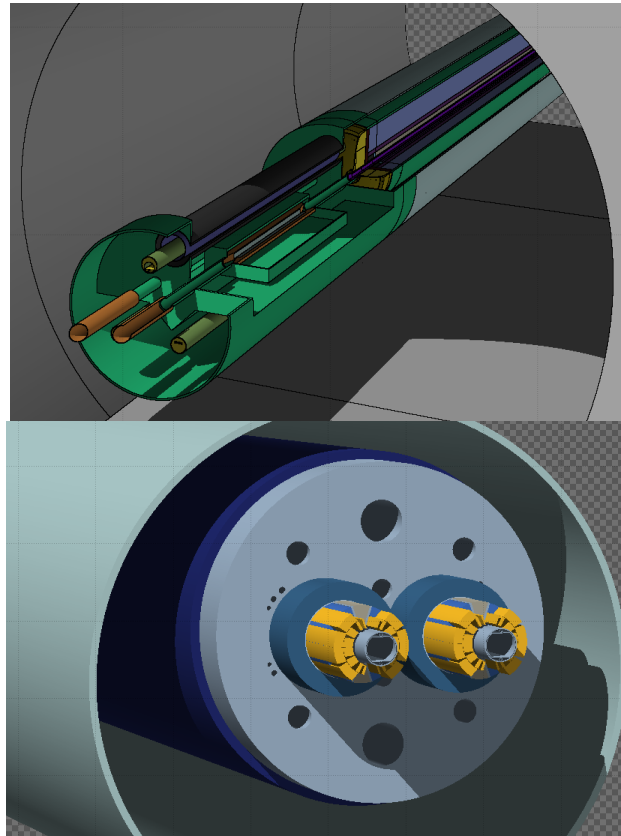

Figure 10 FLUKA models of the 11 T two-in-one dipole and the TCLD collimator assembly (the two figures should be next to each other but my WORD formatting skills are obviously limited).

4.3. ENERGY DEPOSITION RESULTS FOR ION OPERATION (PRELIMINARY)

In the scope of the IR2 energy deposition simulations, different TCLD jaw materials (copper, tungsten) and lengths (0.5-1 m) were studied to investigate the protection efficiency of alternative TCLD specifications. This parametric study was partly motivated by space constraints identified in the context of integration studies. In the following, we focus on the two extreme cases featuring a 0.5 m copper jaw and 1 m tungsten jaw, respectively. Figure 7 shows the peak power density in MBHDP coils due to ion collision debris (BFPP1) impacting on the external TCLD jaw with a mean impact parameter of 2 mm as detailed above. The displayed curves, which correspond to an ALICE upgrade luminosity of $6 \times 10^{27} \text{cm}^{-2} \text{s}^{-1}$, illustrate the difference between the two jaw configurations. In the case of tungsten, the highest power density occurs in the front coil return region (on the opposite side of the vacuum chamber), while in the case of copper the highest value can be observed about 2 m into the magnet (in the coils which are on the same side as the impacted jaw). This qualitative difference can be attributed to the higher transparency of a 0.5 m copper jaw compared to a 1 m tungsten one. With maximum power densities of 3.7mW/cm^3 and 0.9mW/cm^3 , the simulations predict a reduction factor greater than 4 between the two cases. Other jaw configurations, with active absorber lengths between 0.5 and 1 m, can be assumed to yield maximum values within the given range. In either case, the simulations suggest that the peak power densities are safely below the assumed quench limit and eventually allow for a broad margin even in the case of an ALICE luminosity upgrade.

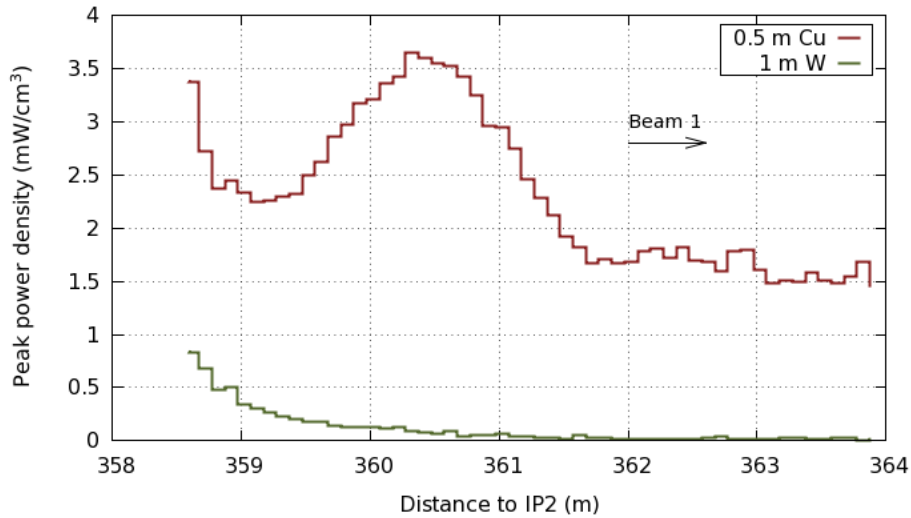

Figure 11 Peak power density in MBHDP coils due to BFBB1 debris impacting on TCLD jaws accommodating either a 0.5 m copper or a 1 m tungsten block. Values apply to an ALICE peak luminosity of $6 \times 10^{27} \text{ cm}^{-2} \text{ s}^{-1}$

For comparison, Figure 8 shows the peak power density in MB coils due to BFPP1 products in case no TCLD collimators are installed. As illustrated in the figure, the pattern follows closely the ion impact distribution on the MB beam screen. The simulation suggests that the maximum power density ($\sim 95 \text{ mW/cm}^3$) lies approximately a factor two above the MB quench limit ($\sim 40 \text{ mW/cm}^3$) inferred from recent quench tests and simulations [ref to Arjan at coll review 2013]. One however needs to account for a certain safety margin which reflects uncertainties in the quench limit and the calculated peak energy density itself. Concerning the latter, one uncertainty could be due to possible variations of beam screen dimensions within allowed tolerances, which could potentially imply a shift of the impact distribution towards the interconnect. Such effects have not yet been studied in detail.

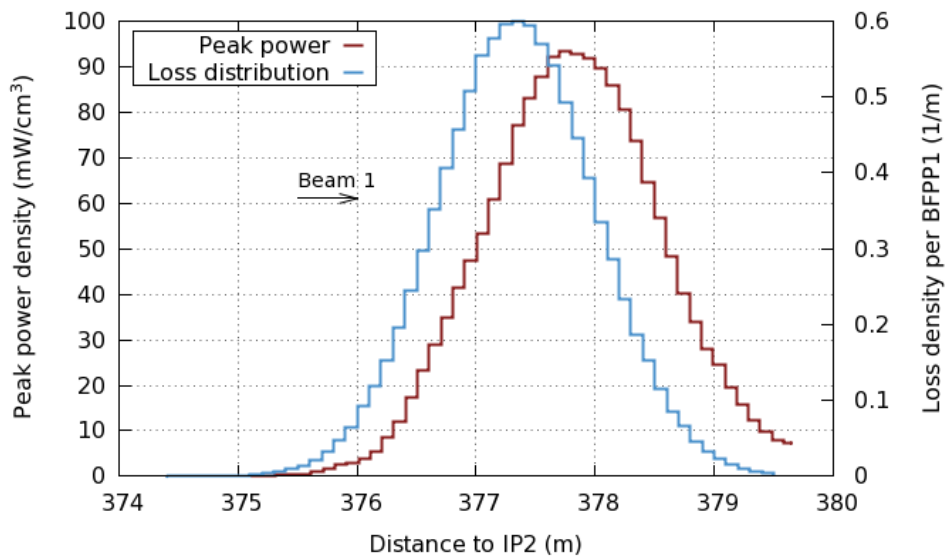

Figure 12 Ion loss distribution (BFPP1) on the MB beam screen as well as the corresponding peak power density in magnet coils for an ALICE peak luminosity of $66 \times 10^{27} \text{ cm}^{-2} \text{ s}^{-1}$

Table 1 summarizes, for both layouts, the calculated peak power densities in magnet coils together with the total power on collimator jaws and magnets due to BFPP1 collision debris.

The reduction factor of peak values in coils is predicted to lie beyond 20 even for a 0.5 m copper jaw. As indicated in the table, the peak power density could be even further decreased if the half gap would be reduced. A noteworthy feature is the power load experienced by the second (non-impacted) jaw, which is, in the case of tungsten, even higher than the load on the downstream magnet.

Table 1 Calculated peak energy density in magnet coils as well as total power on magnets and collimator jaws for different layouts with and without a TCLD collimator. Values only include the contribution due to BFPP1, assuming an ALICE peak luminosity of $6 \times 10^{27} \text{ cm}^{-2} \text{ s}^{-1}$.

Layout	Peak energy density in coils (mW/cm ³)	Reduction factor of peak power density	Total power on magnet	Total power on impacted jaw	Total power on second jaw
MB/no collimator	95	1	105	-	-
MBDHP/TCLD (0.5 m Cu, 43 σ half gap)	3.7	26	46	42	6.5
MBHDP/TCLD (1 m W, 43 σ half gap)	0.8	114	8.4	77	13
MBHDP/TCLD (1 m W, 9 σ half gap)	<0.1	>900	3.0	96	6.5

5. FUTURE PLANS / CONCLUSION / RELATION TO HL-LHC WORK

More realistic simulations including various error models must confirm the results achieved so far: imperfections of the collimation system (jaw tilt and gap errors, imperfect jaw surface, etc.) and of LHC machine (orbit and optics errors, aperture misalignments, ...). Appropriate simulation models were developed in the past for similar studies and they will have to be updated to the new simulation models for HL-LHC layouts.

Energy deposition studies in IR7 with modified DS layouts will be performed for different cases. Further down the line, upgraded designs of the TCLD collimators will also be available which will require updated simulation models.

The new layouts must be studied also against various failure scenarios. Work in this direction has already started within the Valencia team who is contributing by working on a new version of SixTrack to study loads on collimators in case of fast loss scenarios.

In addition to these studies, we will soon start addressing aspects related to the background on the experiments generated by incoming beam halo. The RHUL team will contribute significantly to these studies. Simulation setups for the halo are ready to be used and the geometry of the experiments will be upgraded in synergy with the work of WP10.

REFERENCES

- [1] Fartoukh, S (2011) An achromatic telescopic squeezing (ATS) scheme for the LHC upgrade, IPAC11, WEPC037
- [2] Marsili, A. et al. (2013) Simulations of collimation cleaning performance with HL-LHC optics, IPAC13, Shanghai, China, MOPWO042
- [3] Salvachua, B. et al. (2013) First results of proton collimation quench test. Presentation in the LHC collimation working group,
<https://indico.cern.ch/conferenceDisplay.py?confId=242279>.
- [4] Salvachua, B. et al. (2013) Cleaning performance. Presentation in the LHC collimation review, <https://indico.cern.ch/conferenceOtherViews.py?view=standard&confId=251588>.
- [5] Parma, V et al. (2013) Integration options for collimators in the DS zones. Presentation in the LHC collimation review,
<https://indico.cern.ch/conferenceOtherViews.py?view=standard&confId=251588>.
- [6] Weiler, T. et al. (2008) Beam Cleaning and Beam Loss Control. In Proceedings of HB 2008.
- [7] Wollmann, D. et al. (2010) Predicted performance of combined cleaning with DS-collimators in the LHC. Proceedings of HB2010, Morschach, Switzerland
- [8] Marsili, A. et al. (2013) Collimation cleaning with ATS optics for HL-LHC. Presentation in the LHC collimation review,
<https://indico.cern.ch/conferenceOtherViews.py?view=standard&confId=251588>.
- [9] Bruce, R. et al. (2009), Beam losses from ultraperipheral nuclear collisions between P_b ions in the Large Hadron Collider and their alleviation, *PRSTAB*, **12** 071002
- [10] Steele, G. et al. (2013) Heat load scenarios and protection levels for ions. Presentation in the LHC collimation review,
<https://indico.cern.ch/conferenceOtherViews.py?view=standard&confId=251588>.
- [9] Redaelli, S. et al. (2012) Overview of collimation activities during LS 1. Presentation at the LHC Collimation Working Group Meeting #152,
<https://indico.cern.ch/conferenceDisplay.py?confId=218177>.
- [10] Esposito, L. et al. (2012) Energy deposition studies for TCLs in IR1/5. Presentation at the 2nd Joint HiLumi LHC-LARP Annual Meeting in Frascati,
<http://indico.cern.ch/conferenceTimeTable.py?confId=183635>.
- [11] Ajuirei, I. et al. (2000) Beam losses far downstream of the high luminosity interaction points of LHC. LHC Project Report 398.
- [12] Mokhov, N. et al. (2003) Protection LHC IP1/IP5 components against radiation resulting from colliding beam interactions. LHC Project Report 633.
- [13] Bruce, R. et al. (2009), Beam losses from ultraperipheral nuclear collisions between P_b ions in the Large Hadron Collider and their alleviation, *PRSTAB*, **12** 071002
- [14] Steele, G. et al. (2013) Heat load scenarios and protection levels for ions. Presentation at the LHC Collimation Review 2013,
<https://indico.cern.ch/conferenceOtherViews.py?view=standard&confId=251588>.
- [15] Verweij, A. et al. (2013), Quench limits: extrapolation of quench tests to 7 TeV. Presentation at the LHC Collimation Review 2013,
<https://indico.cern.ch/conferenceOtherViews.py?view=standard&confId=251588>.

ANNEX: GLOSSARY

[You can tabulate all acronyms with their definitions e.g.

Acronym	Definition
DS	Dispersion Suppressor
IR	Interaction Region
IP	Interaction Point
LS1, LS2, LS3	Long-shutdown1, 2, 3