



EDMS NO.
1973028

REV.
0.1

VALIDITY
DRAFT

REFERENCE
LHC-TC-EC-0013

Date: 2017-04-18

ENGINEERING CHANGE REQUEST

Installation in IR7 of Dispersion Suppressor Collimators (TCLD)

BRIEF DESCRIPTION OF THE PROPOSED CHANGE(S):

The main bottleneck of beam losses leaking out of the LHC and HL-LHC collimation insertion (IR7) for betatron cleaning is the dispersion suppressor (DS). In order to reduce these losses, and ensure a smooth operation of the HL-LHC, one new horizontal tungsten collimator (TCLD) will be installed on each side of IR7, in cell 8 of the DS of the outgoing beams. In order to make space for the new collimators, a standard dipole on each side will be replaced by shorter and stronger 11T magnets, as described in a separate ECR.

DOCUMENT PREPARED BY:

R. Bruce, A. Mereghetti,
S. Redaelli

DOCUMENT **TO BE** CHECKED BY:

C. Adorisio, M. Barberan, I. Bejar Alonso,
M. Bernardini, C. Bertone, L. Bottura,
G. Bregliozzi, C. Boccard, S. Bustamante,
J. P. Corso, S. Deleval, B. Delille,
R. de Maria, P. Fessia, R. Folch,
J. F. Fuchs, C. Gaignant, M. Giovannozzi,
G. Girardot, R. Jones, E. Jensen,
J. Jowett, I. Lamas, M. Lamont,
D. Missiaen, Y. Muttoni, M. Nonis,
T. Otto, E. Page, B. Salvant,
F. Savary, R. Steerenberg, D. Tommasini,
L. Tavian, M. Tavlet, C. Vollinger,
C. Zamantzas, M. Zerlauth, J. Wenninger

DOCUMENT **TO BE** APPROVED BY:

P. Collier
(on behalf of the LMC)

L. Rossi
(on behalf of the HL-LHC
project)

DOCUMENT SENT FOR INFORMATION TO:

ATS groups leaders

SUMMARY OF THE ACTIONS TO BE UNDERTAKEN:

[List the main actions to be undertaken]

Note: When approved, an Engineering Change Request becomes an Engineering Change Order.

This document is uncontrolled when printed. Check the EDMS to verify that this is the correct version before use.



1. EXISTING SITUATION AND INTRODUCTION

The present LHC multi-stage betatron collimation system uses primary collimators (TCPs) closest to the beam, which should intercept the primary beam halo, and then secondary collimators (TCSGs) that should intercept the out-scattered secondary halo, and active absorbers (TCLAs) to catch the showers and the tertiary halo. However, if a proton hitting the TCP undergoes single diffractive scattering, it could lose a significant amount of energy without receiving an angular kick large enough to be intercepted by the TCSGs. Such a proton passes all TCSGs and TCLAs but starts to deviate significantly from the main beam in the dispersion suppressor (DS), where the dispersion rises. Similarly, during heavy-ion runs, ions can fragment in the TCP, and out-scattered fragments with large deviations in magnetic rigidity can pass the TCSGs and TCLAs and be lost locally in the DS.

Therefore, the IR7 DS is the main bottleneck in the LHC in terms of losses for both protons and heavy ions. In case of large drops in the beam lifetime, in particular for the case of HL-LHC where the stored energy is almost doubled compared to the LHC, the impacted magnets risk quenching and the beams should be dumped by the BLMs before. This would result in costly downtime and reduced HL-LHC availability and have a negative impact on physics production.

To alleviate the losses for both protons and heavy ions, these last ones for which losses risk to impose larger limitations, additional collimators will be installed in the dispersion suppressors, on the side of the outgoing beam, in the area where the dispersion is already rising [1]. In the HL-LHC baseline, one such collimator, called TCLD, will be installed per side. In order to make space for the collimator, an existing LHC dipole will be removed and replaced by two shorter and stronger 11T magnets, with the collimator fitted in between them.

This document details the installation of the TCLD collimators, foreseen to take place in LS2, while a different ECR (under preparation) describes the installation of the 11T magnets.

2. REASON FOR THE CHANGE

In order to probe the acceptable losses in the IR7 DS, experimental quench tests have been performed [2-6]. The proton quench tests did not result in a quench, however, the heavy-ion test with a 6.37 Z TeV Pb beam resulted in a quench of the dipole MBB.9L7 [6]. This gives a lower limit on the allowed stored beam energy of 10.8 MJ at 6.37 Z TeV, accounting for the specified allowed minimum lifetime of 12 minutes that the collimation system should be able to handle. At the same time, the HL-LHC baseline foresees a stored ion energy of 24 MJ, at the higher energy of 7 Z TeV; at the same time, the quench limit is expected to go down at higher energy. Therefore, mitigations have to be put in place in order to ensure adequate performance of the heavy-ion cleaning.

For protons, FLUKA simulations indicate the peak power density in the most loaded IR7 DS magnet is expected to be about a factor 3 lower than for Pb ions during a 12

minutes lifetime drop [7]. Based on these results, it is estimated that the TCLDs might not be needed for proton operation, however, the error bars are large and it cannot be excluded. Therefore, the installation of one TCLD per side in IR7 is proposed in order to reduce the peak power in the impacted magnets, in accordance also with a previous international review [8].

3. DETAILED DESCRIPTION

Simulations and present knowledge of the quench limits of the standard dipoles as well as the 11 T magnets have shown that the preferred placement of the TCLD is in cell 8 (on the right side of IR7 for B1 and left side for B2) [7]. The standard dipoles to be replaced by the assembly of two 11T magnets are MB.B8R7 and MB.B8L7. The schematic layouts of the present and post-LS2 IR7 dispersion suppressor on the left side of IR7 are shown in Figure 1.

The integration and positions of the two TCLDs are shown in the drawings in Figure 2. More details on the integration are presented in [12].

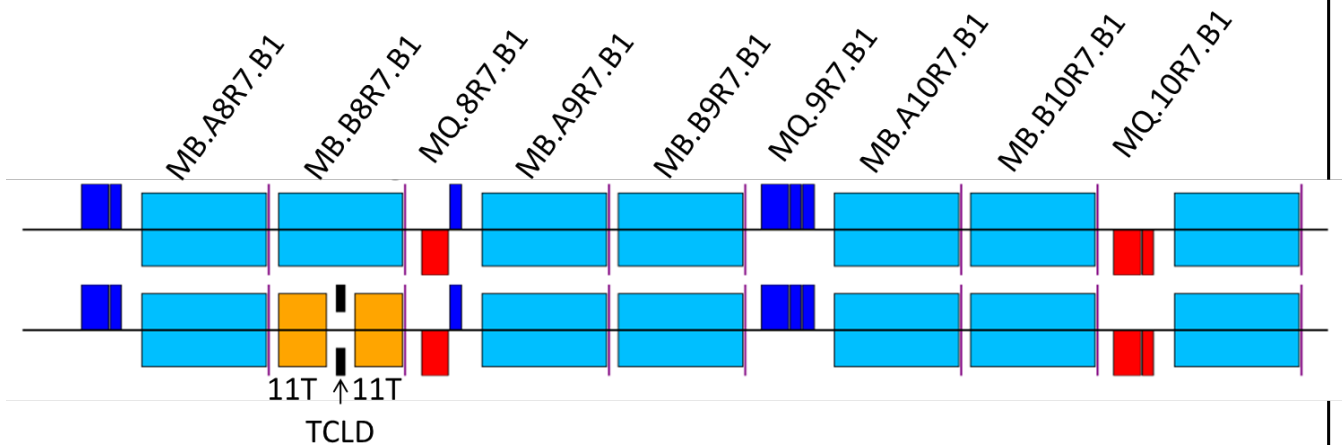

Figure 1 —Schematic layout of the B1 sequence on the left side of IR7 for the pre-LS2 installation (top row) and the proposed post-LS2 installation (bottom row), where MB.B8R7.B1 has been replaced by the assembly of two 11 T dipoles and one TCLD collimator. The layout on the left side of IR7 is fully symmetric. Courtesy of P. Hermes.

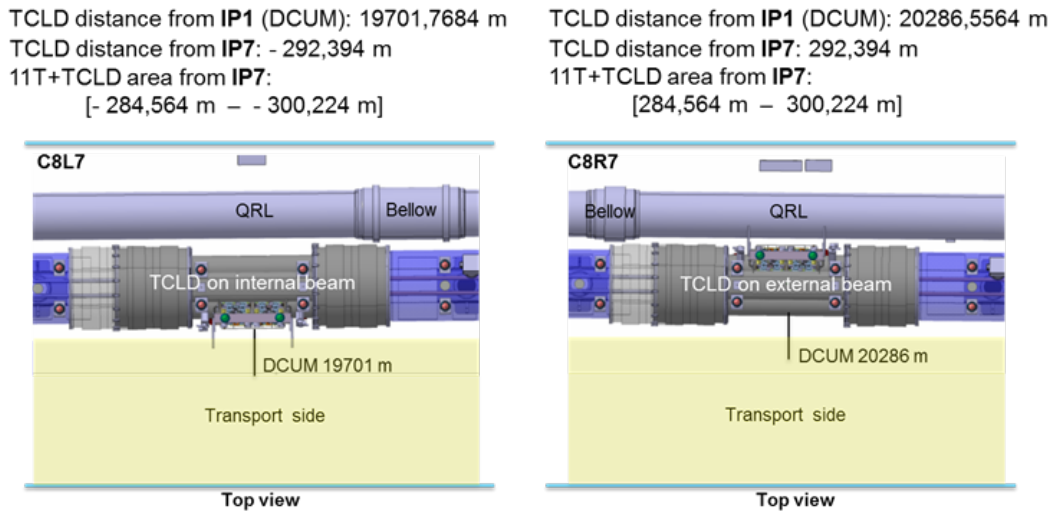

Figure 2 - Positions of new TCLD collimators in IR7. Figure taken from Ref. [12].

The TCLD consists, as most other LHC collimators, of two parallel jaws collimating the beam in the horizontal plane, with the beam passing in between them. The active material of the jaws is the tungsten alloy Inermet 180. The design of the TCLD collimator, shown in more detail in Figure 3 and Figure 4, is derived from the design of the present LHC collimators, but with some differences. Because of the very tight space requirements, the design is challenging and the active length of the material had to be reduced to only 60 cm, in order to make it fit. This means that also a non-standard support design is used. The shorter length has only a minor adverse effect on the downstream energy deposition [10,11]. Furthermore, the bellows at the two longitudinal extremities are integrated in the tank transitions in order to gain longitudinal space. A 3D drawing of the tank and support is shown in Figure 5.

The actuation system does not include any movement in the vertical plane, which allowed to reduce the jaw height. Otherwise, each jaw can be independently moved by two stepping motors per jaw, which maintains the possibility to tilt the jaws in the horizontal plane. The maximum opening of each jaw is 25 mm from the centre, 5 mm less than for standard collimators, and the stroke across the centre is 5 mm.

As all recent collimators, the design includes two BPM buttons per jaw, integrated at the extremities outside of the tapering. The jaws feature water cooling, using squared 9 mm pipes. Each jaw contains also 3 LVDT position sensors and 2 TP100 temperature sensors.

All these require new connections, i.e. pulling new cabling for the motors, including LVDTs and temperature sensors. Cables should be pulled also for the BPMs, which should be connected to the standard DOROS electronics as for other collimators. Furthermore, the water cooling has to be connected to the demineralized water circuit, in series with the other collimators. A new tapping for incoming and outgoing water with a valve on each line is needed. Furthermore, next to each TCLD, a standard LHC BLM should be installed, for use during beam-based alignment and in order to monitor local beam losses.

The characteristics of the TCLD are summarized in Table 1. The layout names for the new collimators and the names of the embedded BPMs are listed in Table 2.

The TCLD will be integrated in a specially designed assembly, containing a beam pipe for the other beam, as well as a cryo-bypass, which is needed since the TCLD is a warm element placed between two cold ones. This assembly is shown in Figure 6 and the full installation including the two 11T dipoles is shown in Figure 7.

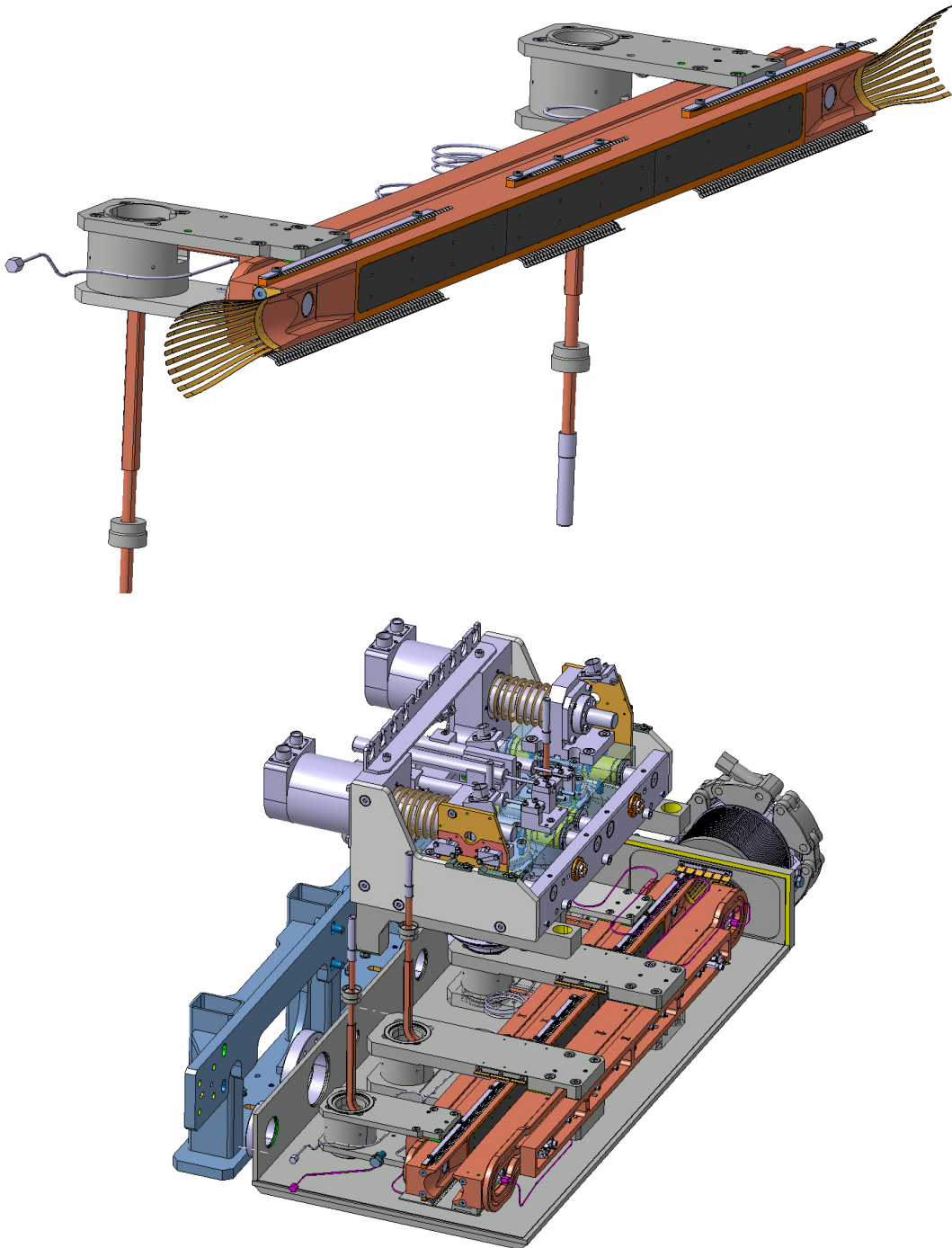

Figure 3 – Drawing of one of the TCLD jaws (top), including RF fingers, cooling pipes and BPMs, and the two jaws installed on the table (bottom). Courtesy of L. Gentini.

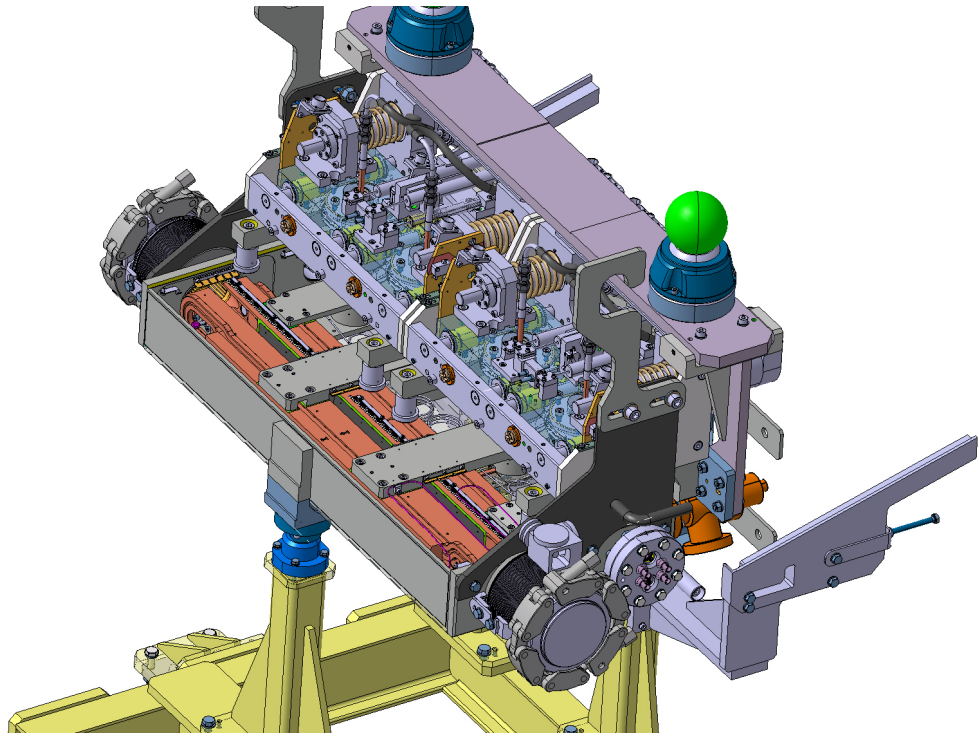

Figure 4 — 3D drawing of the TCLD jaws, integrated in the tank. Courtesy of L. Gentini.

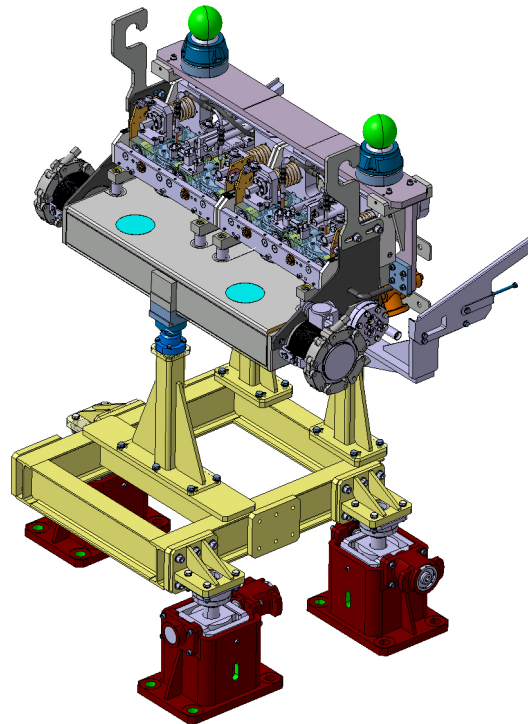

Figure 5 – 3D drawing of the TCLD tank and support. Courtesy of L. Gentini.

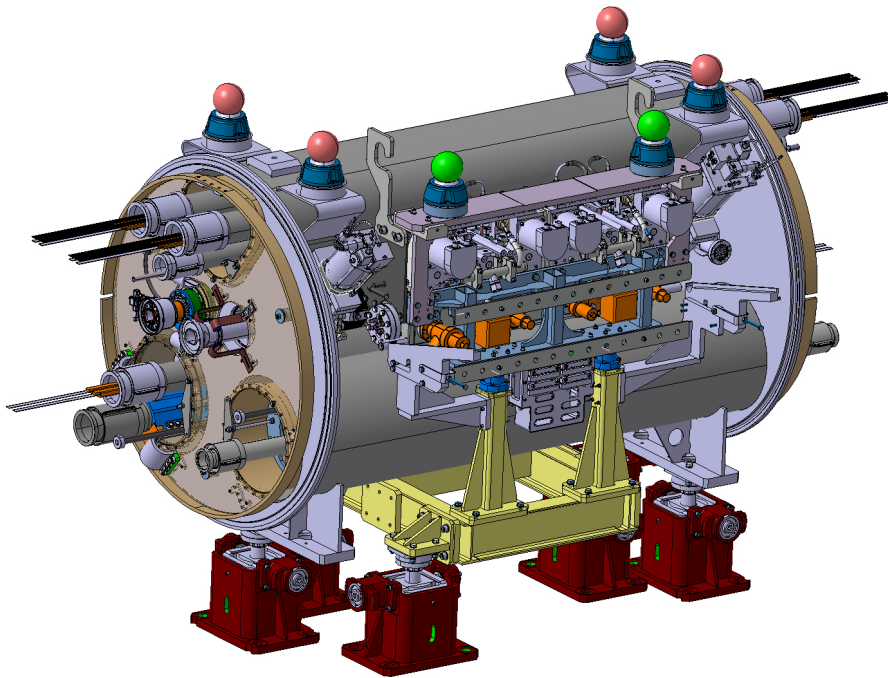

Figure 6 – The assembly to be installed between the two 11T dipoles, consisting of TCLD collimator, support, beam pipe for the other beam, and cryo-bypass. Courtesy of L. Gentini.

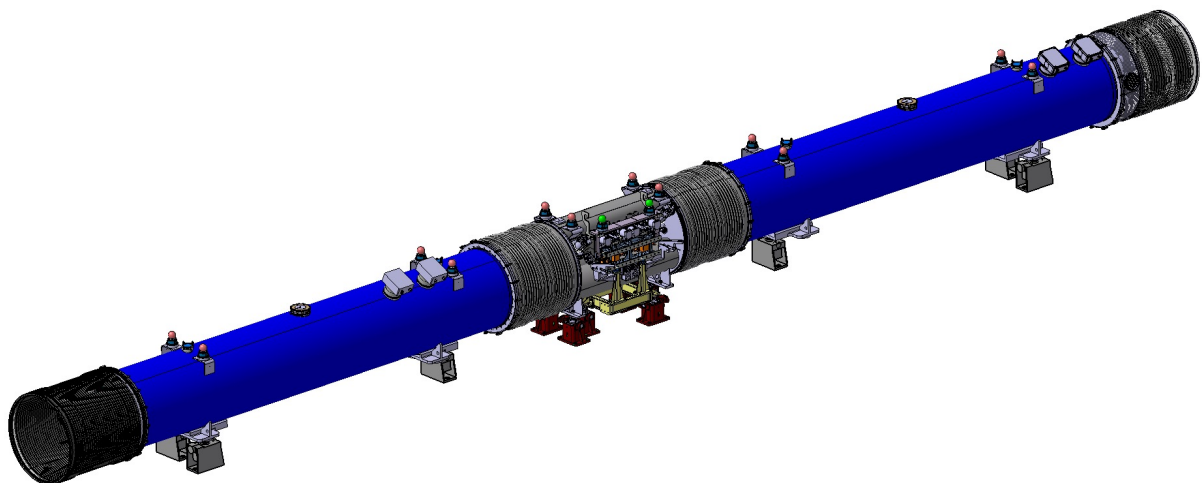

Figure 7 – A 3D drawing of the two 11T dipoles, with the collimator assembly installed in the middle.

Table 1 — Detailed parameters of the TCLD collimator.

Characteristics	Units	Value
Jaw active length	mm	600
Jaw absorbing material	-	Inermet 180
Flange-to-flange distance	mm	1080
Number of jaws	-	Two
Orientation	-	Horizontal
Number of BPMs per jaw	-	Two
RF damping	-	RF fingers
Cooling of the jaw	-	Yes
Cooling of the vacuum tank	-	No
Minimum gap	mm	<2
Maximum gap	mm	50
Stroke across zero	mm	5
Number of motors per jaw	-	Two
Angular adjustment	-	Yes
Transverse jaw movement (fifth axis)	-	No

Table 2 — Layout name, collimator azimuthal angle and plane, and in-jaw BPM names.

Collimator layout name	Azimuthal angle [deg]	Collimation plane	Name BPM upstream	Name BPM downstream	Name BPM tank
TCLD.8R7.B1	0	H	LHC.BPTUH.8R7.B1	LHC.BPTDH.8R7.B1	--
TCLD.8L7.B2	0	H	LHC.BPTUH.8L7.B2	LHC.BPTDH.8L7.B2	--



4. IMPACT ON OTHER ITEMS

4.1 IMPACT ON ITEMS/SYSTEMS

BE/BI	BE/BI support is required for the BLM acquisition associated to the collimator. One additional beam loss monitors (BLMs) is required downstream of each TCLD for beam-based alignment purposes. BE/BI is responsible for the BPM acquisition. Cables should be pulled for the new BPMs. DOROS control units should be installed for the signal processing.
BE/OP	New devices will have to be properly configured in the top level control layer of LSA.

4.2 IMPACT ON UTILITIES AND SERVICES

Raw water:	No
Demineralized water:	The circuit of cooling water of the TCLD will have to be connected, in series to other collimators. New tapping required.
Compressed air:	No
Electricity, cable pulling (power, signal, optical fibres...):	New cables are required for the motors, LVDTs and temperature sensors. New cables required for BPMs are described in the previous section. New cable for BLM might be required.
DEC/DIC:	RQF0842047 (EN/SMM) RQF0912378 (BE/BI)
Vacuum (bake outs, sectorisation...):	The TCLD has to pass standard vacuum qualification procedures before installation in the tunnel.
Special transport/handling:	No
Temporary storage of conventional/radioactive components:	No
Survey:	Standard alignment procedures apply - at installation, the collimator position should be adjusted by the survey team.
Scaffolding:	No
Controls:	The LHC control system must be updated to include the new collimator and BPMs.
GSM/WIFI networks:	No
Cryogenics:	The implementation of the cryo-bypass is described in the companion ECR by WP11 (under preparation).
Contractor(s):	No
Others:	



5. IMPACT ON COST, SCHEDULE AND PERFORMANCE

5.1 IMPACT ON COST

Detailed breakdown of the change cost:	The activity is funded by the HL-WP5, unit 5.2 (DS cleaning)
Budget code:	Various codes across the ATS sectors: 53701: HL-LHC WP05-DS Collimation-EN/STI 53709: HL-LHC WP05-DS Collimation-EN/STI [CONS] 53718: HL-LHC WP05-DS Collimation-EN/SMM 53722: HL-LHC WP05-DS Collimation-EN/SMM [CONS] 64073: HL-LHC WP05-DS Collimation-BE/BI 53707: HL-LHC WP05 Collimator production TCLD-TE/VSC

5.2 IMPACT ON SCHEDULE

Proposed installation schedule:	Installation foreseen during 2020
Proposed test schedule (if applicable):	Prior to installation: controls tests (EN/STI) and vacuum validation (TE/VSC). Impact on the EN/EL team to be evaluated.
Estimated duration:	<i>Detail by Inigo.</i>
Urgency:	--
Flexibility of scheduling:	Limited. Determined by the installation of 11T dipoles.

5.3 IMPACT ON PERFORMANCE

Mechanical aperture:	The movable collimator will (intentionally) be operated at smaller aperture than the previous beam pipe in the removed dipole, in order to intercept beam losses that otherwise would hit the downstream magnets. This will, however, not have any negative influence on the global aperture.
Impedance:	The impedance has been studied by the impedance team for a preliminary design and no issues were found. Checks of the final design are on-going.
Electron cloud (NEG coating, solenoid...)	No change
Insulation (enamelled flange, grounding...)	No change
Vacuum performance:	No change. The collimator will be qualified by VCS before installation.
Others:	

6. IMPACT ON OPERATIONAL SAFETY

6.1 ÉLÉMENT(S) IMPORTANT(S) DE SECURITÉ



Requirement	Yes	No	Comments
EIS-Access		X	--
EIS-Beam		X	--
EIS-Machine		X	--

6.2 OTHER OPERATIONAL SAFETY ASPECTS

Have new hazards been created or changed?	no
Could the change affect existing risk control measures?	no
What risk controls have to be put in place?	none
Safety documentation to update after the modification	
Define the need for training or information after the change	

7. WORKSITE SAFETY

7.1 ORGANISATION

Requirement	Yes	No	Comments
IMPACT – VIC:	X		
Operational radiation protection (surveys, DIMR...):	X		Installation in high radiation environment must be done by taking the ALARA principle into account.
Radioactive storage of material:		X	--
Radioactive waste:		X	--
Fire risk/permit (IS41) (welding, grinding...):		X	
Alarms deactivation/activation (IS37):		X	
Others:			



7.2 REGULATORY TESTS

Requirement	Yes	No	Responsible Group	Comments
Pressure/leak tests:	<input type="checkbox"/>	<input checked="" type="checkbox"/>		
Electrical tests:	<input type="checkbox"/>	<input checked="" type="checkbox"/>		
Others:	<input type="checkbox"/>	<input type="checkbox"/>		

7.3 PARTICULAR RISKS

Requirement	Yes	No	Comments
Hazardous substances (chemicals, gas, asbestos...):	<input type="checkbox"/>	<input checked="" type="checkbox"/>	
Work at height:	<input type="checkbox"/>	<input checked="" type="checkbox"/>	
Confined space working:	<input type="checkbox"/>	<input checked="" type="checkbox"/>	
Noise:	<input type="checkbox"/>	<input checked="" type="checkbox"/>	
Cryogenic risks:	<input checked="" type="checkbox"/>	<input type="checkbox"/>	Warm collimator to be installed between two cold elements with cryo bypass
Industrial X-ray (<i>tirs radio</i>):	<input type="checkbox"/>	<input checked="" type="checkbox"/>	
Ionizing radiation risks (radioactive components):	<input type="checkbox"/>	<input type="checkbox"/>	[Traceability by TREC.]
Others:	<input type="checkbox"/>	<input type="checkbox"/>	

8. FOLLOW-UP OF ACTIONS BY THE TECHNICAL COORDINATION

Action	Done	Date	Comments
Carry out site activities:	<input type="checkbox"/>		
Carry out tests:	<input type="checkbox"/>		
Update layout drawings:	<input type="checkbox"/>		
Update equipment drawings:	<input type="checkbox"/>		
Update layout database:	<input type="checkbox"/>		
Update naming database:	<input type="checkbox"/>		
Update optics (MADX)	<input type="checkbox"/>		



Update procedures for maintenance and operations			
Update Safety File according to EDMS document 1177755 :			
Others:			

9. REFERENCES

- [1] G. Apollinari, I. Bejar Alonso, O. Bruning, P. Fessia, M. Lamont, L. Rossi, and L. Tavian (editors). High-Luminosity Large Hadron Collider (HL-LHC): Technical Design Report V. 0.1. CERN Yellow Reports: Monographs. CERN-2017-007-M. CERN, Geneva, 2017
- [2] R.W. Assmann, et al. Collimator losses in the DS of IR7 and quench test at 3.5 TeV. CERN-ATS-Note-2011-042 MD, 2011
- [3] S. Redaelli, et al. Quench Tests at the Large Hadron Collider with Collimation Losses at 3.5 Z TeV. Proceedings of the 52nd ICFA Advanced Beam Dynamics Workshop on High-Intensity and High-Brightness Hadron Beams (HB2012), Beijing, China, 2012
- [4] B. Salvachua, et al. Collimation quench test with 4 TeV proton beams. CERN-ACC-NOTE-2014-0036, 2014
- [5] B. Salvachua, et al. Collimation quench test with 6.5 TeV proton beams. CERN-ACC-NOTE-2016-0015, 2016
- [6] P.D. Hermes, et al. LHC Heavy-Ion Collimation Quench Test at 6.37Z TeV. CERN-ACC-NOTE-2016-0031, 2016
- [7] C. Bahamonde Castro, et al. Update on energy deposition for IR7 for HL-LHC. Presentation at the 7th HL-LHC Collaboration Meeting, Madrid, Spain (2017)
- [8] LHC Collimation Review 2013
<https://indico.cern.ch/event/251588/timetable/?view=standard>
- [10] E. Skordis et al., Updated power deposition simulations for DS collimators in IR7, Presentation at the Collimation Upgrade Specification Meeting 30/01/2015, <https://indico.cern.ch/event/366694/>
- [11] G. Steele et al., Preliminary results of the FLUKA TCLD study (IR7), Presentation at the Collimation Upgrade Specification Meeting 18/10/2013, <http://indico.cern.ch/conferenceDisplay.py?confId=278104>
- [12] M. Gonzalez de la Aleja, HL-LHC INTEGRATION REPORT FOR INSTALLATION APPROVAL, CERN EDMS document 1903950