



LHC

EDMS NO. 1973028	REV. 0.2	VALIDITY DRAFT
----------------------------	--------------------	--------------------------

REFERENCE
LHC-TC-EC-0013

Date: 2018-08-26

ENGINEERING CHANGE REQUEST

Installation in IR7 of Dispersion Suppressor Collimators (TCLD)

BRIEF DESCRIPTION OF THE PROPOSED CHANGE(S):

The main bottleneck of beam losses leaking out of the LHC and HL-LHC collimation insertion (IR7) for betatron cleaning is the dispersion suppressor (DS). In order to reduce these losses, and ensure a smooth operation of the HL-LHC, one new horizontal tungsten collimator (TCLD) will be installed on each side of IR7, in cell 8 of the DS of the outgoing beams. In order to make space for the new collimators, a standard dipole on each side will be replaced by shorter and stronger 11T magnets, as described in a separate ECR.

This activity is within the scope of the HL-LHC project (WP5).

DOCUMENT PREPARED BY: R. Bruce, A. Mereghetti, S. Redaelli	DOCUMENT TO BE CHECKED BY: C. Adorisio, M. Barberan, I. Bejar Alonso, M. Bernardini, C. Bertone, C. Boccard, L. Bottura, G. Bregliozzi, S. Bustamante, J. P. Corso, S. Deleval, B. Delille, R. de Maria, P. Fessia, R. Folch, J. F. Fuchs, C. Gaignant, M. Giovannozzi, G. Girardot, E. Jensen, R. Jones, J. Jowett, I. Lamas, M. Lamont, D. Missiaen, Y. Muttoni, M. Nonis, T. Otto, E. Page, G. Pigny, B. Salvant, F. Savary, R. Steerenberg, L. Tavian, M. Tavlet, D. Tommasini, C. Vollinger, J. Wenninger, C. Zamantzas, M. Zerlauth.	DOCUMENT TO BE APPROVED BY: P. Collier (on behalf of the LMC) L. Rossi (on behalf of the HL-LHC project)
--	--	--

DOCUMENT SENT FOR INFORMATION TO:

ATS groups leaders

SUMMARY OF THE ACTIONS TO BE UNDERTAKEN:

Note: When approved, an Engineering Change Request becomes an Engineering Change Order.
This document is uncontrolled when printed. Check the EDMS to verify that this is the correct version before use.



1. EXISTING SITUATION AND INTRODUCTION

The present LHC multi-stage betatron collimation system uses primary collimators (TCPs) closest to the beam, which should intercept the primary beam halo, and then secondary collimators (TCSGs) that should intercept the out-scattered secondary halo, and active absorbers (TCLAs) to catch the showers and the tertiary halo. However, if a proton hitting the TCP undergoes single diffractive scattering, it could lose a significant amount of energy without receiving an angular kick large enough to be intercepted by the TCSGs. Such a proton passes all TCSGs and TCLAs but starts to deviate significantly from the main beam in the dispersion suppressor (DS), where the dispersion rises. Similarly, during heavy-ion runs, ions can fragment in the TCP, and out-scattered fragments with large deviations in magnetic rigidity can pass the TCSGs and TCLAs and be lost locally in the DS.

Therefore, the IR7 DS is the main bottleneck in the LHC in terms of losses for both protons and heavy ions. In case of large drops in the beam lifetime, in particular for the case of HL-LHC where the stored energy is almost doubled compared to the LHC, the impacted magnets risk quenching and the beams should be dumped by the BLMs before. This would result in costly downtime and reduced HL-LHC availability and have a negative impact on physics production.

Although the beam intensity limitations are more severe in the case of heavy ions, these losses are significant for proton beams as well. To mitigate their effects, additional collimators will be installed in the dispersion suppressors, on the side of the outgoing beam, in the area where the dispersion starts to rise [1]. In the HL-LHC baseline, one such collimator, called TCLD, will be installed per side. In order to make space for the collimator, an existing LHC dipole will be removed and replaced by two shorter and stronger 11T magnets, with the collimator fitted in between them.

This document details the installation of the TCLD collimators, foreseen to take place in LS2, while a different ECR [2] describes the installation of the 11T magnets.

2. REASON FOR THE CHANGE

In order to probe the acceptable losses in the IR7 DS, experimental quench tests have been performed [3-7]. The proton quench tests did not result in a quench, however, the heavy-ion test with a 6.37 Z TeV Pb beam resulted in a quench of the dipole MBB.9L7 [7]. This gives a lower limit on the allowed stored beam energy of 10.8 MJ at 6.37 Z TeV, accounting for the specified allowed minimum lifetime of 12 minutes that the collimation system should be able to handle. At the same time, the HL-LHC baseline foresees a stored ion energy of 24 MJ, at the higher energy of 7 Z TeV; at the same time, the quench limit is expected to go down at higher energy. Therefore, mitigations have to be put in place in order to ensure adequate performance of the heavy-ion cleaning.

For protons, FLUKA simulations indicate the peak power density in the most loaded IR7 DS magnet is expected to be about a factor 3 lower than for Pb ions during a 12 minutes lifetime drop [8]. Based on these results, it is estimated that the TCLDs might

not be needed for proton operation, however, the error bars are large and it cannot be excluded. Therefore, the installation of one TCLD per side in IR7 is proposed in order to reduce the peak power in the impacted magnets, in accordance also with a previous international review [9]. It should be recalled that full mitigation of the losses from heavy-ion collimation might ultimately require two collimators on each side of IR7. However it is only possible to install one at present and this should already provide the bulk of the potential alleviation.

3. DETAILED DESCRIPTION

On each side in the DS region at point 7, one standard 14.3 m dipole with 8.33 T field will be replaced by an assembly consisting of a pair of 5.5 m-long 11 T dipoles surrounding the bypass cryostat (length 2.2 m) and the TCLD collimator in the middle. The installation of the 11 T dipoles and the cryo-bypass is described in a separate ECR under the responsibility of WP11 [2].

Simulations and present knowledge of the quench limits of the standard dipoles as well as the 11 T magnets have shown that the preferred placement of the TCLD is in cell 8 (on the right side of IR7 for B1 and left side for B2) [8]. The standard dipoles to be replaced by the assembly of two 11T magnets are MB.B8R7 and MB.B8L7. The schematic layouts of the present and post-LS2 IR7 dispersion suppressor on the left side of IR7 are shown in Figure 1.

The integration and positions (DCUM) of the two TCLDs are shown in the drawings in Figure 2. More details on the integration are presented in [12], although this document (version from March 2018) will be updated in September 2018 with the very latest design and installation additions.

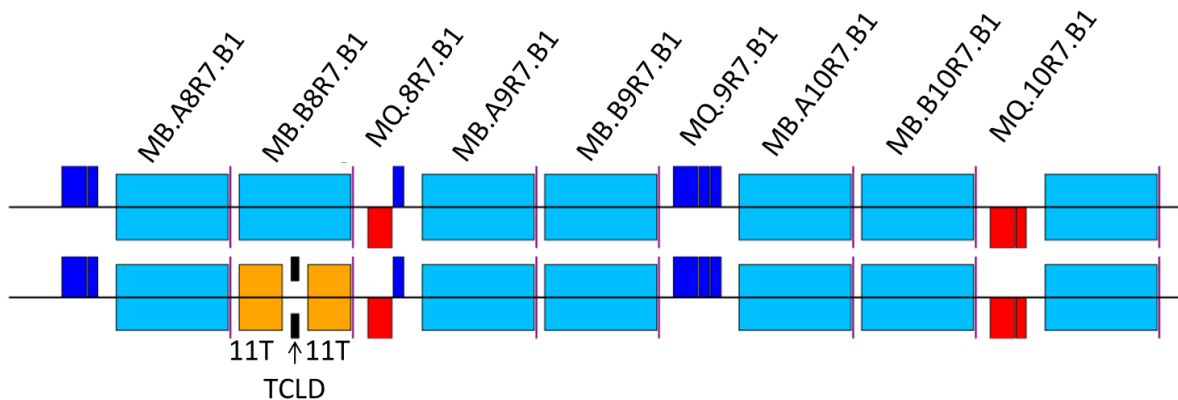

Figure 1 —Schematic layout of the B1 sequence on the right side of IR7 for the pre-LS2 installation (top row) and the proposed post-LS2 installation (bottom row), where MB.B8R7.B1 has been replaced by the assembly of two 11 T dipoles and one TCLD collimator. The layout on the left side of IR7 is fully symmetric. Courtesy of P. Hermes.

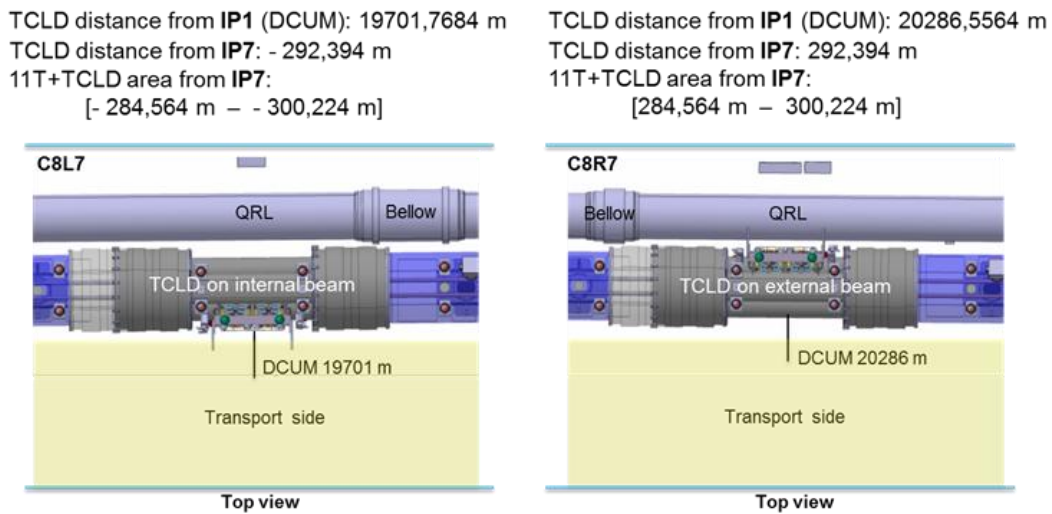

Figure 2 - Positions of new TCLD collimators in IR7. Figure taken from Ref. [12].

Like most other LHC collimators, the TCLD consists of two parallel jaws collimating the beam in the horizontal plane, with the beam passing in between them. The active material of the jaws is the tungsten alloy Inermet 180. The design of the TCLD collimator, shown in more detail in Figure 3 and Figure 4, is derived from the design of the present LHC collimators, but with some differences. Because of the very tight space requirements, the design is challenging and the active length of the material had to be reduced to only 60 cm, in order to make it fit. This also means that a non-standard support design is used. The shorter length has only a minor adverse effect on the downstream energy deposition [10, 11]. Furthermore, the bellows at the two longitudinal extremities are integrated in the tank transitions in order to gain longitudinal space. Special tooling for transport, handling and for the retraction of the collimator bellows during the installation has been designed. In order to gain as much space around the TCLD vacuum tank as possible, a new thinner set of heating jackets (aerogel) has also been produced. A 3D drawing of the tank and support is shown in Figure 5. The SmarTeam references are shown in Table 1.

Table 1 SmartTeam references for the TCLD.

Element	SmarTeam reference
Model of the TCLD collimator	STST0694095
Model of the TCLD support	ST1023729
Model of the TCLD jacks	ST0943265

The actuation system does not include any movement in the vertical plane, allowing the jaw height to be reduced. Otherwise, each jaw can be independently moved by two stepping motors per jaw, which maintains the possibility to tilt the jaws in the horizontal plane. The maximum opening of each jaw is 25 mm from the centre, 5 mm less than for standard collimators, and the stroke across the centre is 5 mm.

As all recent collimators, the design includes two BPM buttons per jaw, integrated at the extremities outside of the tapering. The jaws feature water cooling, using squared

9 mm pipes. Each jaw contains also 3 LVDT position sensors and 2 TP100 temperature sensors.

All these require new connections, i.e. pulling new cabling for the motors, including LVDTs and temperature sensors. Cables should be pulled also for the BPMs, which should be connected to the standard DOROS electronics as for other collimators. Furthermore, the cooling water has to be connected to the demineralized main water circuit, directly to the LHC main lines. A new tapping for incoming and outgoing water with a valve on each extremity of the line is needed. Furthermore, next to each TCLD, a standard LHC BLM should be installed, for use during beam-based alignment and in order to monitor local beam losses.

The characteristics of the TCLD are summarized in Table 2. The layout names for the new collimators and the names of the embedded BPMs are listed in Table 3. The TCLD will be integrated in a specially designed assembly, containing a beam pipe for the other beam, as well as a cryo-bypass, which is needed since the TCLD is a warm element placed between two cold ones. This assembly is shown in Figure 7 and the full installation including the two 11T dipoles is shown in Figure 8. The vacuum flange used for the TCLD is the DN100 with internal diameter of 64 mm. For the TCLD of R7 only, it is needed to include a standard LHC bridge (removable) and a platform above the QRL in order to provide an easy access to the rear side of the TCLD to complete the installation and for future maintenance [12].

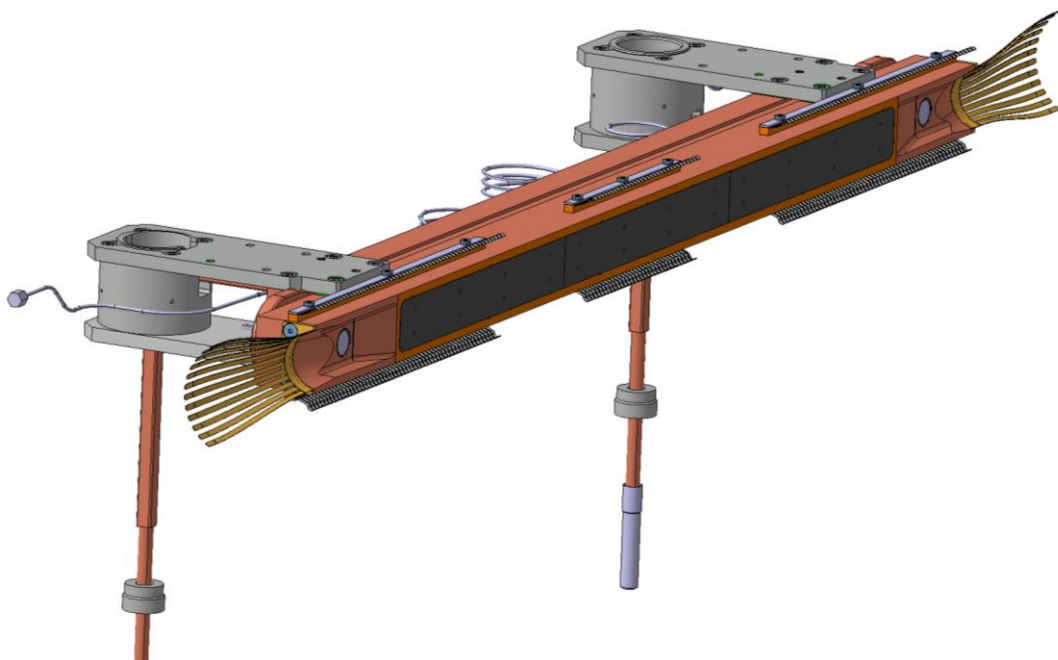

Figure 3 — Drawing of one of the TCLD jaws, including RF fingers, cooling pipes and BPMs. Courtesy of L. Gentini – SmarTeam numbers ST0676575 (L7) and ST0918055 (R7).

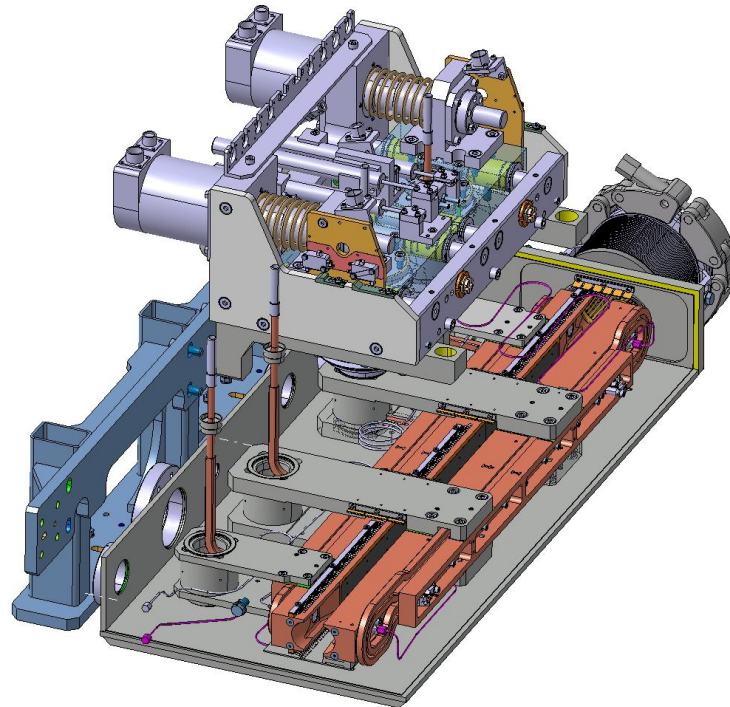

Figure 4 – Drawing of one of the two TCLD jaws installed on the table. Courtesy of L. Gentini – SmarTeam numbers ST0676575 (L7) and ST0918055 (R7).

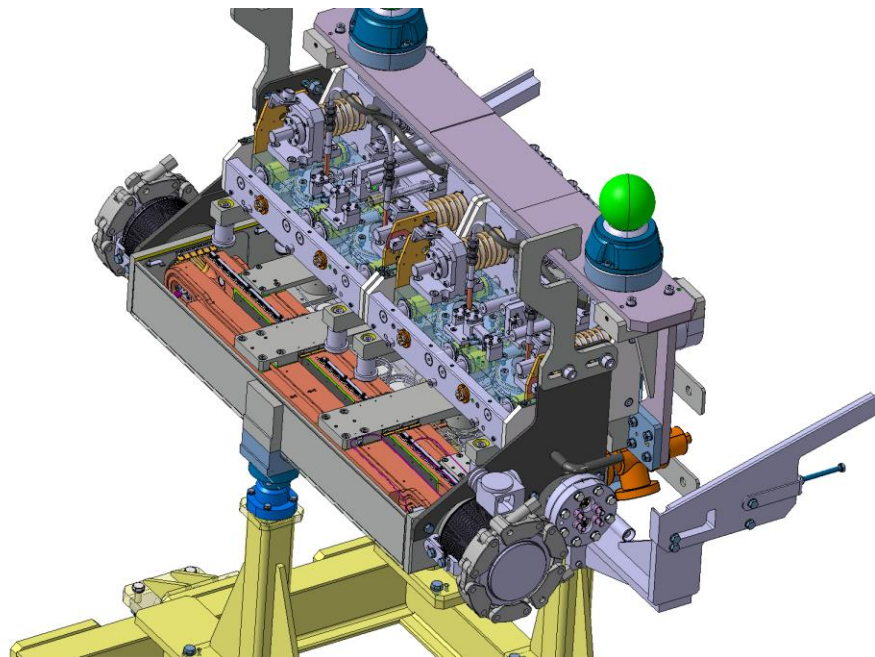

Figure 5 — 3D drawing of the TCLD jaws, integrated in the tank. Courtesy of L. Gentini – SmarTeam numbers ST0676575 (L7) and ST0918055 (R7).

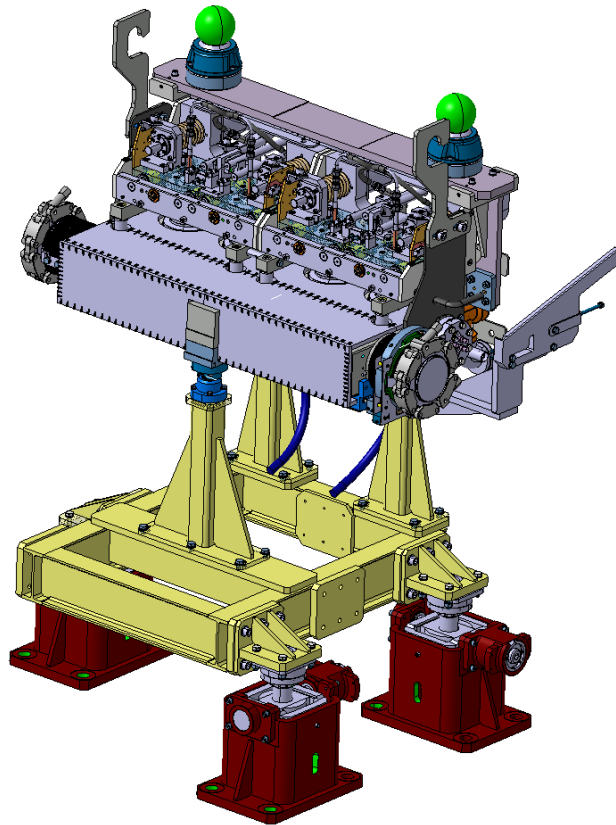

Figure 6 – 3D drawing of the TCLD tank and support. Courtesy of L. Gentini – SmarTeam numbers ST0676575 (L7) and ST0918055 (R7).

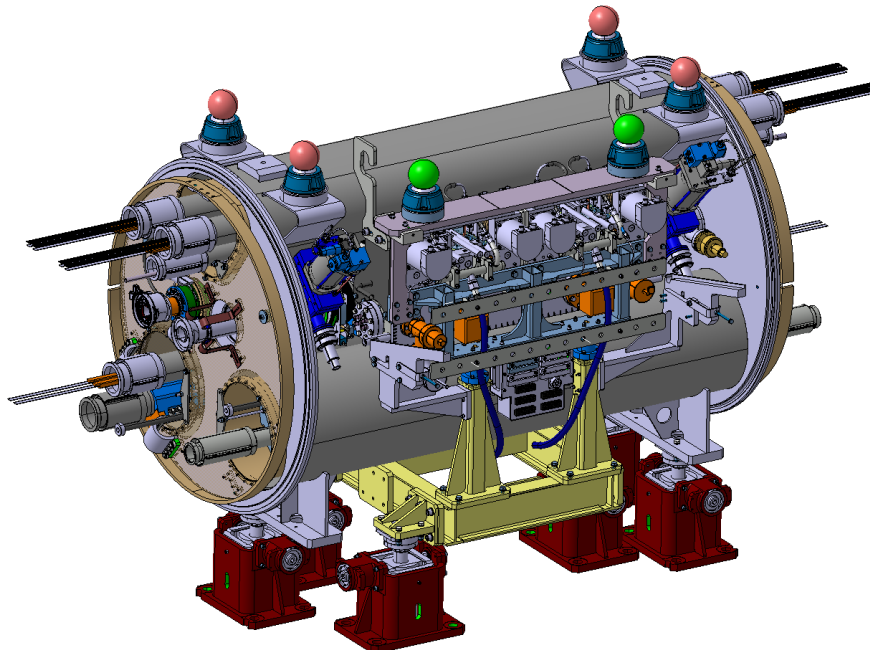

Figure 7 – The assembly to be installed between the two 11T dipoles, consisting of TCLD collimator, support, beam pipe for the other beam, and cryo-bypass. Courtesy of L. Gentini – SmarTeam numbers ST0676575 (L7) and ST0918055 (R7).

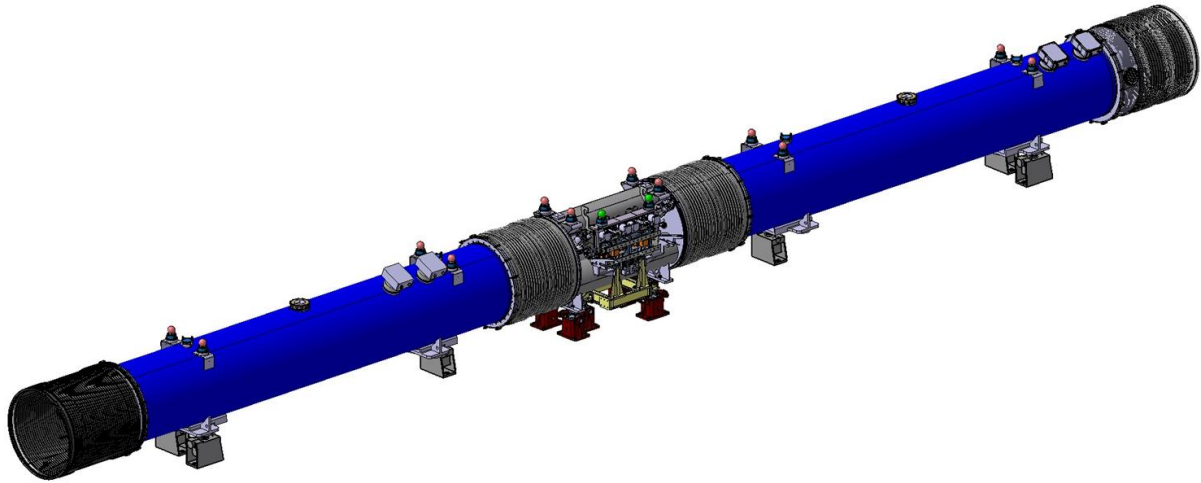

Figure 8 – A 3D drawing of the two 11T dipoles, with the collimator assembly installed in the middle.

Table 2 — Detailed parameters of the TCLD collimator.

Characteristics	Units	Value
Jaw active length	mm	600
Jaw absorbing material	-	Inermet 180
Flange-to-flange distance	mm	1080
Number of jaws	-	Two
Orientation	-	Horizontal
Number of BPMs per jaw	-	Two
RF damping	-	RF fingers
Cooling of the jaw	-	Yes
Cooling of the vacuum tank	-	No
Minimum gap	mm	<2
Maximum gap	mm	50
Stroke across zero	mm	5
Number of motors per jaw	-	Two
Angular adjustment	-	Yes
Transverse jaw movement (fifth axis)	-	No

Table 3 — Layout name, collimator azimuthal angle and plane, and in-jaw BPM names.

Collimator layout name	Azimuthal angle [deg]	Collimation plane	Name BPM upstream	Name BPM downstream	Name BPM tank
TCLD.8R7.B1	0	H	LHC.BPTUH.8R7.B1	LHC.BPTDH.8R7.B1	--
TCLD.8L7.B2	0	H	LHC.BPTUH.8L7.B2	LHC.BPTDH.8L7.B2	--

3.1 Vacuum Layout Changes

The installation of the TCLD's will require the addition of two sector valves, which have a 63 mm inner diameter of the aperture. Consequently, VACSEC67.R and VACSEC78.B will be both divided into three new vacuum sectors as seen on Table 4 and Table 5.

With a dual purpose, these tables indicate the start and end DCUM of the new sectors and the vacuum instrumentation to be added to the TCLD and sector valves.

Table 4 - New Vacuum Sectorization in ARC6-7

CURRENT SECTOR	NEW SECTOR	NAME	LENGTH (m)	DCUM START (m)	DCUM END (m)	NOTES
VACSEC67.B (External beam line)	VACSEC67.B		2807.2914	16928.5420	19735.8334	
VACSEC67.R (Internal Beam Line)	VACSECA67.R		2772.5824	16928.5420	19701.1244	
		VVGSL	0.1040	19701.1244	19701.2284	VGPB
	VACSECB67.R	TCLD	1.0800	19701.2284	19702.3084	VVFMD, VPNNG, VPNNG, VGFC
		VVGSR	0.1040	19702.3084	19702.4124	VGPB
	VACSECC67.R		33.4210	19702.4124	19735.8334	

Table 5 - New Vacuum Sectorization in ARC7-8

CURRENT SECTOR	NEW SECTOR	NAME	LENGTH (m)	DCUM START (m)	DCUM END (m)	NOTES
VACSEC78.R (Internal Beam Line)	VACSEC78.R		2817.4114	20252.6464	23070.0578	
VACSEC78.B (External beam line)	VACSECA78.B		33.2660	20252.6464	20285.9124	
		VVGSR	0.1040	20285.9124	20286.0164	VGPB
	VACSECB78.B	TCLD	1.0800	20286.0164	20287.0964	VVFMD, VPNNG, VPNNG, VGFC
		VVGSL	0.1040	20287.0964	20287.2004	VGPB
	VACSECC78.B		2782.8574	20287.2004	23070.0578	

The introduction of a new sectorization implies the existence of a pumping port and vacuum instrumentation on each sector. Since there are no pumping ports between the LSS (Q7 side) and the TCLD, new pumping ports and vacuum instrumentation must be added as described on a separate ECR [13], where the same approach is suggested both for Point 2 and Point 7.

4. IMPACT ON OTHER ITEMS

4.1 IMPACT ON ITEMS/SYSTEMS

BE/BI	<p>BE/BI support is required for the BLM acquisition associated to the collimator. One additional beam loss monitors (BLMs) is required downstream of each TCLD for beam-based alignment purposes.</p> <p>BE/BI is responsible for the BPM acquisition. Cables should be pulled for the new BPMs. DOROS control units should be installed for the signal processing.</p>
-------	--



TE/VSC	The installation of the TCLDs will require the installation of vacuum components adjacent to the collimators. In addition, new vacuum instrumentation has to be installed and cabled. This improvement will ultimately introduce two new vacuum sectors on each side of point 7 with the installation of two sector valves per side.
BE/OP	New devices will have to be properly configured in the top level control layer of LSA.
WP11	The installation of the TCLD is tightly linked to the installation of the 11T dipole and cryo-bypass, under the responsibility of WP11 [2] (constraints on geometry, schedule, functionality, etc).

4.2 IMPACT ON UTILITIES AND SERVICES

Raw water:	No
Demineralized water:	The water cooling circuit of the TCLD will have to be connected to the main water circuit. New tapping, valves and water hoses are required. The new collimators have the same requirements as the present ones and will not add new requirements on the cooling water flows.
Compressed air:	Compressed air should be available at the TCLD location. TE-VSC needs it for driving the vacuum sector valves and the temporary pumping group.
Electricity, cable pulling (power, signal, optical fibres...):	New cables are required for the motors, LVDTs and temperature sensors. New cables required for BPMs are described in the previous section. New cable for BLM might be required. Displacement of top electrical boxes is needed (interference with handling tooling during installation). Installation of 3 new electrical boxes is needed for bake-out purposes.
DEC/DIC:	RQF0842047 (EN/SMM) RQF0912378 (BE/BI) RQF0912887 (TE/VSC) Racks: 3 BI racks at TZ76 (BY01, BY02, BY03) for BPM, and TYCHL05 for controls
Vacuum (bake outs, sectorisation...):	Sector valves will be installed at each extremity of the TCLD. Once the TCLD is installed, TE-VSC must install the bake-out equipment, perform the bake-out and finally remove all the components for a total of about 2-3 weeks of work per vacuum sector.
Special transport/handling:	Dedicated transport and installation tooling as well as installation procedure.
Temporary storage of conventional/radioactive components:	No
Survey:	Standard alignment procedures apply - at installation, the collimator position should be adjusted by the survey team. Marking position on the floor is needed. The component must be created / updated in the CERN layout database before any SU activities in the LHC tunnel. - EN-SMM-ASG section will mark on the floor the beam axis and the beam points (start / end) of the component (0.5 day / component) : the floor need to be cleared (and cleaned ?) before the tracing. - EN-SMM-ASG section will not marked the drilling positions : a drilling drawing ("plan de perçage") with respect to the both beam references marked on the floor by SU will be needed by EN/ACE - The alignment (0.5 day / component) should be done before the vacuum



	<p>connection and after the magnets (11T / connection cryostat) alignment The alignment of the TCLD and cryo-bypass will be carried out from the both adjacent dipoles. In the future, when the adjacent magnets will be re-aligned (vertical or radial displacements) during LHC smoothing campaigns the TCLD and the cryo-bypass will also need to be realigned</p>
Scaffolding:	No
Controls:	<ul style="list-style-type: none"> - The LHC control system must be updated to include the new collimator and BPMs. - The SCADA vacuum control system has to be updated accordingly to the proposed tables and should integrate new vacuum sectors, sector valves, pumps and gauges.
GSM/WIFI networks:	No
Cryogenics:	The implementation of the cryo-bypass is described in the companion ECR by WP11) [2].)
Contractor(s):	No
Layout DB:	<p>The Layout DB should be updated on the optical side and for the new vacuum valves, pumps, gauges and vacuum sectorization. New component codes have to be created for the new sector valves (see Tables 3 and 4)</p>
Others	For the TCLD of R7 only, it is needed to include a standard LHC bridge (removable) and a platform above the QRL in order to provide an easily access to the rear side of the TCLD to complete the installation and for future maintenance

5. IMPACT ON COST, SCHEDULE AND PERFORMANCE

5.1 IMPACT ON COST

Detailed breakdown of the change cost:	The activity is funded by the HL-WP5, unit 5.2 (DS cleaning)
Budget code:	<p>Various codes across the ATS sectors:</p> <p>53701: HL-LHC WP05-DS Collimation-EN/STI 53709: HL-LHC WP05-DS Collimation-EN/STI [CONS] 53718: HL-LHC WP05-DS Collimation-EN/SMM 53722: HL-LHC WP05-DS Collimation-EN/SMM [CONS] 64073: HL-LHC WP05-DS Collimation-BE/BI 53707: HL-LHC WP05 Collimator production TCLD-TE/VSC</p>

5.2 IMPACT ON SCHEDULE

Proposed installation schedule:	<p>Installation foreseen during 2020 Readiness to install date: 5th March 2020</p>
Proposed test schedule (if applicable):	<p>Prior to installation: controls tests (EN/STI) and vacuum validation (TE/VSC). Impact on the EN/EL team to be evaluated.</p> <p>The new handling equipment is ready and the installation procedure will be available mid-September.</p>



Estimated duration:	2-3 weeks
Urgency:	--
Flexibility of scheduling:	Limited. Determined by the installation of 11T dipoles. With the present understanding, no specific safety constraints apply if the installation is done as planned with the sector warm. In case of change of schedule, a safety assessment shall be performed.

5.3 IMPACT ON PERFORMANCE

Mechanical aperture:	The movable collimator will (intentionally) be operated at smaller aperture than the previous beam pipe in the removed dipole, in order to intercept beam losses that otherwise would hit the downstream magnets. This will, however, not have any negative influence on the global aperture.
Impedance:	The impedance has been studied by the impedance team for a preliminary design and no issues were found. Checks of the final design are on-going. The impedance team requires an impedance measurement with the stretched wire technique for all produced collimators (in addition to the validation of the design that was performed through measurements on prototypes) to detect potential impedance non-conformities before installation. The EN/STI team assessed that this activity is compatible with the present planning. Implications on the budgets are estimated to less than 2 kCHF per collimator that can be absorbed by the general WP5 budget (BC 61071). A risk assessment is being organised to identify other potential implications, in particular on the vacuum conformity of the collimators, before taking a final decision on the feasibility and strategy of these measurements.
Optics/MADX	Changes in the layout DB should be propagated to the MAD-X LHC sequence.
Electron cloud (NEG coating standard)	No change
Insulation (enamelled flange, grounding...)	No change
Vacuum performance:	TE-VSC will perform vacuum acceptance tests on each component to assess vacuum compatibility within LHC vacuum environment based on EDMS 1752123. In case of non-conformity the collimators could be rejected and not being installed.
Others:	

6. IMPACT ON OPERATIONAL SAFETY

6.1 ÉLÉMENT(S) IMPORTANT(S) DE SECURIT

Requirement	Yes	No	Comments
EIS-Access		X	--



EIS-Beam		X	--
EIS-Machine		X	--

6.2 OTHER OPERATIONAL SAFETY ASPECTS

The TCLD Safety Assessment Form is available on EDMS 1900519.

<p>Have new hazards been created or changed?</p>	<p>The TCLD doesn't introduce new hazard during its operation.</p> <p>An additional risk assessment using the FMEA method (EDMS 1969909) is being finalised to assess the risks during installation, bake-out, regular maintenance and exceptional replacement during run periods.</p> <p>For exceptional replacement during run periods, relevant arc sectors and cryo bypass must be emptied from liquid helium and heated up to 20K before TCLD exchange. This could be reconsidered if transport can demonstrate that their handling procedure guarantees the highest safety level. For the TCLD right of IR7, the same requirements apply to the QRL.</p> <p>Access to the TCLD at C8R7 require the installation of a passerelle over the beam line and a mechanical protection of the QRL.</p>
<p>Could the change affect existing risk control measures?</p>	<p>Access to the QRL side shall be secured.</p>
<p>What risk controls have to be put in place?</p>	<p>The FMEA will help assessing the risk control measures to implement to prevent a He spill during installation, bake-out, regular maintenance and exceptional replacement. Preliminary conclusions indicate that in case of exceptional replacement during runs, the sector shall be warmed up to 20K. A procedure for the regular maintenance will be issued by EN-SMM and EN-STI. Bake-out safety constraints will be defined once the TE-VSC thermal simulations will be available.</p> <p>A structural analysis shall demonstrate that the <i>passerelle</i> and platform are conforming and safe for access.</p>
<p>Safety documentation to update after the modification</p>	<p>Procedures for installation, bake-out, regular maintenance and exceptional replacement shall be updated wrt the conclusions of the FMEA. They also shall mention access condition for the TCLD on C8R7.</p>
<p>Define the need for training or information after the change</p>	<p>The modus operandi to intervene on the TCLD shall be communicated to the intervening workers.</p>

7. WORKSITE SAFETY

7.1 ORGANISATION

Requirement	Yes	No	Comments
IMPACT – VIC:	X		
Operational radiation protection (surveys, DIMR...):	X		Installation in high radiation environment must be done by taking the ALARA principle into account.



Radioactive storage of material:		X	--
Radioactive waste:		X	--
Fire risk/permit (IS41) (welding, grinding...):		X	
Alarms deactivation/activation (IS37):		X	
Others:			

7.2 REGULATORY TESTS

Requirement	Yes	No	Responsible Group	Comments
Pressure/leak tests:	X		Responsible of cooling water circuits. TE-VSC	Water pressure test of cooling pipes must be done, as specified, before vacuum acceptance test. All cooling pipes must be emptied for the vacuum test. Any water leakage during the bake out could induce short circuits and permanent damage of the bake out system. Helium leak test of the complete collimator before and after bake out cycle is performed.
Electrical tests:		X		
Others:	X			The impedance should be measured and validated - see section 5.3.

7.3 PARTICULAR RISKS

Requirement	Yes	No	Comments
Hazardous substances (chemicals, gas, asbestos...):		X	
Work at height:		X	
Confined space working:		X	
Noise:		X	
Cryogenic risks:	X		Warm collimator to be installed between two cold elements with cryo bypass
Industrial X-ray (<i>tirs radio</i>):	X		X-rays of the TCLD bellow after installation must be performed
Ionizing radiation risks (radiative components):			
Others:			



8. FOLLOW-UP OF ACTIONS BY THE TECHNICAL COORDINATION

Action	Done	Date	Comments
Carry out site activities:			
Carry out tests:			
Update layout drawings:			
Update equipment drawings:			
Update layout database:			
Update naming database:			
Update optics (MADX)			
Update procedures for maintenance and operations			
Update Safety File according to EDMS document 1177755 :			
Others:			

9. REFERENCES

- [1] G. Apollinari, I. Bejar Alonso, O. Bruning, P. Fessia, M. Lamont, L. Rossi, and L. Tavian (editors). High-Luminosity Large Hadron Collider (HL-LHC): Technical Design Report V. 0.1. CERN Yellow Reports: Monographs. CERN-2017-007-M. CERN, Geneva, 2017
- [2] D. Schoerling, Installation of the 11 T Dipole Full Assembly in LHC P7 (HL-LHC WP11), EDMS LHC-LBH-EC-0001 or 1995306, 2018
- [3] R.W. Assmann, et al. Collimator losses in the DS of IR7 and quench test at 3.5 TeV. CERN-ATS-Note-2011-042 MD, 2011
- [4] S. Redaelli, et al. Quench Tests at the Large Hadron Collider with Collimation Losses at 3.5 Z TeV. Proceedings of the 52nd ICFA Advanced Beam Dynamics Workshop on High-Intensity and High-Brightness Hadron Beams (HB2012), Beijing, China, 2012
- [5] B. Salvachua, et al. Collimation quench test with 4 TeV proton beams. CERN-ACC-NOTE-2014-0036, 2014
- [6] B. Salvachua, et al. Collimation quench test with 6.5 TeV proton beams. CERN-ACC-NOTE-2016-0015, 2016
- [7] P.D. Hermes, et al. LHC Heavy-Ion Collimation Quench Test at 6.37Z TeV. CERN-ACC-NOTE-2016-0031, 2016



[8] C. Bahamonde Castro, et al. Update on energy deposition for IR7 for HL-LHC. Presentation at the 7th HL-LHC Collaboration Meeting, Madrid, Spain (2017)

[9] LHC Collimation Review 2013

<https://indico.cern.ch/event/251588/timetable/?view=standard>

[10] E. Skordis et al., Updated power deposition simulations for DS collimators in IR7, Presentation at the Collimation Upgrade Specification Meeting 30/01/2015, <https://indico.cern.ch/event/366694/>

[11] G. Steele et al., Preliminary results of the FLUKA TCLD study (IR7), Presentation at the Collimation Upgrade Specification Meeting 18/10/2013, <http://indico.cern.ch/conferenceDisplay.py?confId=278104>

[12] M. Gonzalez de la Aleja, HL-LHC INTEGRATION REPORT FOR INSTALLATION APPROVAL, CERN EDMS document 1903950

[13] G. Bregliozzi et al., Engineering Change Request: New Vacuum Pumping Ports in the ARCs linked to the 11T and TCLDs Installation, CERN EDMS Document No. 1966384