



LHC

EDMS NO. 1973224	REV. 0.1	VALIDITY DRAFT
----------------------------	--------------------	--------------------------

REFERENCE LHC-TC-EC-0015

Date: 2018-04-05

ENGINEERING CHANGE REQUEST

**Upgrade Of The Crystal Collimation
Test Stand in IR7**

BRIEF DESCRIPTION OF THE PROPOSED CHANGE(S):

Four crystal primary (TCPC) collimators are installed in IR7 for collimation studies. The installation took place in various phases in the Long Shutdown 1 (LS1) and in two year-end technical stops in 2016 and 2017. Beam tests with this equipment, which in Run II was only compatible with setup beams, will continue until the end of 2018. In particular, crucial tests are expected with lead ion beams at the end the run. Depending on these results, adding crystal collimation to the baseline of the HL-LHC WP5 upgrade plan might be considered. This document describes the changes needed in LS2 if this upgrade is confirmed.

DOCUMENT PREPARED BY: S. Redaelli (BE-ABP) R. Bruce (BE-ABP) A. Mereghetti (BE-ABP)	DOCUMENT CHECKED BY: O. Aberle, C. Adorisio, G. Arduini, M. Barberan, I. Bejar Alonso, M. Bernardini, G. Bregliozzi, S. Bustamante, M. Calviani, F. Carra, G. Cattenoz, P. Chiggiato, J.-P. Corso, B. Delille, R. De Maria, P. Fessia, R. Folch, J.-F. Fuchs, S. Gabourin, C. Gaignant, S. Gilardoni, M. Giovannozzi, R. Jones, I. Lamas, M. Lamont, A. Masi, D. Missiaen, Y. Muttoni, T. Otto, E. Page, S. Roesler, B. Salvant, J. Sestak, R. Steerenberg, L. Tavian, M. Tavlet, C. Vollinger, J. Wenninger, C. Zamantzas.	DOCUMENT APPROVED BY: P. Collier (on behalf of the LMC) L. Rossi (on behalf of the HL-LHC project)
--	---	--

DOCUMENT SENT FOR INFORMATION TO:

LMC participants, Collimation working group, Collimation Upgrade Specification working group, Machine Protection working group, ATS groups leaders

SUMMARY OF THE ACTIONS TO BE UNDERTAKEN:

Note: When approved, an Engineering Change Request becomes an Engineering Change Order.
This document is uncontrolled when printed. Check the EDMS to verify that this is the correct version before use.



1. EXISTING SITUATION AND INTRODUCTION

Crystal collimation is being studied as a possible improvement of the LHC collimation system for HL-LHC [1]. Bent crystals might be used as primary collimators (TCPs) to channel halo particles onto a single collimator absorber, as opposed to the present TCPs that scatter halo particles onto several secondary collimators. This scheme is particularly interesting for heavy-ion beam collimation.

Four crystal primary collimators (TCPCs) are presently installed in IR7 in a test stand that has been operational since the beginning of the LHC Run II. The installation of this system was carried out in three campaigns detailed in [2,3,4]:

- LS1: initial installation of two TCPC on beam 1 and preparation of cables for possible upgrade of the system (new detectors) [2];
- EYETS2016-17 (Extended Year-End Technical Stop 2016-17): installation of equivalent layouts on beam 2 [3];
- YETS2017 (Year-End Technical Stop 2017-18): replacement of one malfunctioning TCPC (beam 2 horizontal).

The present layout names, DCUM and vacuum sector of the crystal collimators are summarized in the table below:

Existing TCPC	DCUM	Vacuum Sector
TCPCV.A6R7.B2	20144	B5R7.R
TCPCH.A5R7.B2	20090	A5R7.R
TCPCH.4L7.B1	19919	A4L7.B
TCPCV.A6L7.B1	19843	B5L7.B

Important beam tests are expected at the end of 2018 when crystal collimation will be tested with lead ion beams. If tests are successful, crystal collimation might be integrated in the baseline of the HL-LHC-WP5 collimation upgrade.

This document describes the changes requested for a possible upgrade of the system in LS2. In the most demanding scenario, considered conservatively in this document, works could entail the replacement of all 4 TCPC assemblies to upgrade the hardware and / or the crystals mounted in the present goniometers. It is noted that the installation on beam 1 presents some non-conformities that were tolerated for the first installation but need to be replaced for future changes (see detailed discussion in [3]).

2. REASON FOR THE CHANGE

Pending an experimental assessment with ion beams at the end of 2018, crystal collimation is being considered for the HL-LHC upgrade of ion collimation [5,6]. Specifically, crystal collimation is considered as a possible improvement of the present upgrade baseline for dispersion suppressor (DS) cleaning around IR7, within WP5. As a result of the 2016 re-baselining of the HL-LHC project [5], the DS upgrade now involves the insertion of 1 "TCLD" collimator and 2 11 T dipoles that will replace the dipoles MBB.8 at either side of IR7 [7]. The upgrade initially planned involved a

second unit in cell 10. Removing this second unit does not cure fully the losses in the DS, and for ion beams we cannot exclude the risk of quenching these magnets in standard operation.

Crystal collimation is seen as a possible “adiabatic” change of the IR7 layout to mitigate this problem. In fact, contrary to the high intensity proton case, the channelled ion halos can be safely disposed of with the present secondary collimators without need of dedicated high-power absorbers. We would therefore need only 4 crystal assemblies for the betatron cleaning of both beams and planes.

3. DETAILED DESCRIPTION

At this stage, we assume that the design of the TCPC assembly remains very similar to the presently installed hardware, see Figure 1. It relies on a movable replacement chamber that allows inserting the crystal close to the beam only in its “out” position. In standard operation for proton beams, this replacement chamber will be in its “in” position and hide the crystal from the circulating beam.

As a design requirement, possible design modifications from the present hardware must fit into the present installation slots, so that the present assemblies can be replaced with minor changes (as for example it was described in [4]). At this stage, we also assume that no additional controls cabling is required and that the present ones will be used in case new TCPCs are installed.

The detailed description of which one(s) of the 4 TCPCs shall be changed in LS2 will follow after the experiments’ results in the LHC, through an update of this document. At this stage, we assume conservatively – for resource estimates – that all the 4 TCPCs shall be replaced.

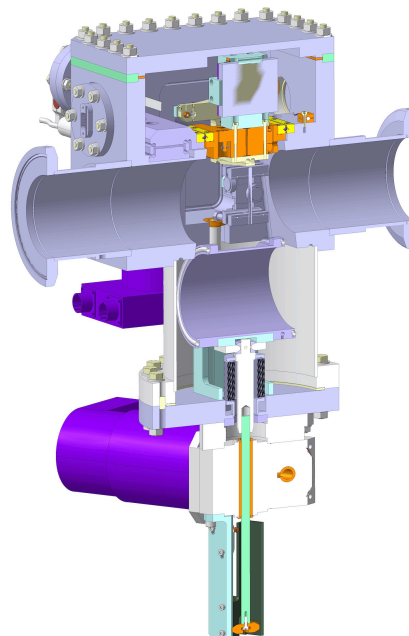

Figure 1 — 3D view of the horizontal goniometer setup: the crystal can be inserted into the beam only when the C-shape replacement chamber is moved out (on the bottom in the figure). The 3D reference corresponding to the crystal collimator in the horizontal configuration is the ST0563346_01.



4. IMPACT ON OTHER ITEMS

4.1 IMPACT ON ITEMS/SYSTEMS

LHC collimation system	No significant changes with respect to the system as of 2017-2018, as new TCPC assemblies will replace existing ones.
BE/BI	The present BLM system requires no further modifications in case of a TCPC replacement. The possibility to improve the present diamond BLM acquisition for fast loss measurements is also under evaluation (optional). This would provide bunch-by-bunch measurements at crystal locations.
Machine protection	A change of interlocking strategy was deployed in the YETS2017 [4] that involved adding position limits for the crystal (upgrading the first implementation that relied on a mask-able interlock based on the "out" switch status). After the operational experience in 2018, we will assess if further modifications are needed.
BE/OP	No significant changes from the present implementation in the control system.
TE/VSC	No impact on the adjacent vacuum components.

4.2 IMPACT ON UTILITIES AND SERVICES

Raw water:	No.
Demineralized water:	No.
Compressed air:	No.
Electricity, cable pulling (power, signal, optical fibres...):	No.
DEC/DIC:	No.
Racks (name and location):	No.
Vacuum (bake outs, sectorisation...):	For each crystal/goniometer the entire vacuum sector must be vented, the bakeout installed and finally NEG activation for a total of about 3.5 wks of work per vacuum sector. In addition to tunnel activities: Vacuum acceptance test of the 4 TCPC
Special transport/handling:	The crystal/goniometer assembly is extremely delicate, and shall be transported, installed and aligned similarly to the recommendations of document [2] written for the goniometers previously installed on B1.
Temporary storage of conventional/radioactive components:	-
Alignment and positioning:	After installation, the new goniometer should be properly fiducialized by the Survey team.
Scaffolding:	Not needed.



Controls:	-
GSM/WIFI networks:	-
Cryogenics:	No.
Contractor(s):	N/A
Surface building(s):	N/A
Layout DB:	In case of changes of crystals, the layout database names will remain that same as presently defined.

5. IMPACT ON COST, SCHEDULE AND PERFORMANCE

5.1 IMPACT ON COST

Detailed breakdown of the change cost:	All activities will be covered by WP5.
Budget code:	HL-LHC-WP5 code 61072 shall be used for any preparatory activity. On the other hand, the full approval discussed in this document is subject to a change of baseline of HL-LHC-WP5. If this happens, this will entail a definition of an appropriate budget structure.

5.2 IMPACT ON SCHEDULE

Proposed installation schedule:	Installation towards the end of LS2 would be favourable. TE-VSC: These vacuum sectors are closed (External or internal beam line) or even the same sector of the upgrade proposed for the TCSPM and TCCPM. Following the ALARA principle it is necessary to regroup the VSC activities of bake-out a NEG activation.
Proposed test schedule (if applicable):	Prior to installation: control test (EN/SMM), vacuum validation (TE/VSC), fiducialization (EN/SMM).
Estimated duration:	<1 week installation time for EN/STI group. TE-VSC Estimation indicated before.
Urgency:	--
Flexibility of scheduling:	Hardware is unlikely to be available before the end of 2019.

5.3 IMPACT ON PERFORMANCE

Mechanical aperture:	No impact as the new hardware is the same in this respect.
Impedance:	The layout with replacement chamber has been already evaluated and approved by the impedance team. No problems were observed for the high-intensity operation when the installed goniometers on Beam 1 and Beam 2 were in their OUT position. Studies are ongoing to assess if the new goniometer design in the IN position can be compatible also with operation at higher intensities. The operational experience in 2018 will also be taken into account.



Optics/MADX	-
Electron cloud (NEG coating, solenoid...)	-
Insulation (enamelled flange, grounding...)	-
Vacuum performance:	TE-VSC will perform vacuum acceptance tests on each component to assess vacuum compatibility within LHC vacuum environment based on EDMS 1752123. In case of not conformity the collimators could be rejected and not being installed.
Others:	-

6. IMPACT ON OPERATIONAL SAFETY

6.1 ÉLÉMENT(S) IMPORTANT(S) DE SECURITÉ

Requirement	Yes	No	Comments
EIS-Access	<input type="checkbox"/>	<input checked="" type="checkbox"/>	-
EIS-Beam	<input type="checkbox"/>	<input checked="" type="checkbox"/>	-
EIS-Machine	<input type="checkbox"/>	<input checked="" type="checkbox"/>	-

6.2 OTHER OPERATIONAL SAFETY ASPECTS

Have new hazards been created or changed?	No.
Could the change affect existing risk control measures?	No.
What risk controls have to be put in place?	None.
Safety documentation to update after the modification	-
Define the need for training or information after the change	-

7. WORKSITE SAFETY

7.1 ORGANISATION

Requirement	Yes	No	Comments
IMPACT – VIC:	<input type="checkbox"/>	<input checked="" type="checkbox"/>	



Operational radiation protection (surveys, DIMR...):	x		<p>Installation in high radiation environment must be done by taking the ALARA principle into account.</p> <p>TE-VSC: Dedicated WDP should be prepared and validated by RP for each step of the installation: mechanical, bake-out and NEG activation.</p>
Radioactive storage of material:	x		<p>Removed TCPC assembly should be considered as radioactive equipment (or put in a radioactive storage). Possibility to work on the TCPC now in the tunnel (e.g. to replace the crystals) is being assessed.</p>
Radioactive waste:		x	
Fire risk/permit (IS41) (welding, grinding...):		x	
Alarms deactivation/activation (IS37):		x	
Others:			

7.2 REGULATORY TESTS

Requirement	Yes	No	Responsible Group	Comments
Pressure/leak tests:	X		TE-VSC	Helium leak test of the complete collimator before and after bake out cycle is performed.
Electrical tests:	X		EN/STI	Standard controls tests for movement functionality.
Others:				

7.3 PARTICULAR RISKS

Requirement	Yes	No	Comments
Hazardous substances (chemicals, gas, asbestos...):		x	
Work at height:		x	
Confined space working:		x	
Noise:		x	
Cryogenic risks:		x	
Industrial X-ray (<i>tirs radio</i>):		x	
Ionizing radiation risks (radioactive components):		x	
Others:			



8. FOLLOW-UP OF ACTIONS BY THE TECHNICAL COORDINATION

Action	Done	Date	Comments
Carry out site activities:			
Carry out tests:			
Update layout drawings:			
Update equipment drawings:			
Update layout database:			
Update naming database:			
Update optics (MADX)			
Update procedures for maintenance and operations			
Update Safety File according to EDMS document 1177755 :			
Others:			

9. REFERENCES

- [1] G. Apollinari, I. Bejar Alonso, O. Brüning, P. Fessia, M. Lamont, L. Rossi, and L. Tavian (editors). High-Luminosity Large Hadron Collider (HL-LHC): Technical Design Report V. 0.1. CERN Yellow Reports: Monographs. CERN-2017-007-M. CERN, Geneva, 2017.
- [2] S. Montesano, J. Lendaro, F. Loprete, R. Losito, A. Masi, D. Mirarchi, S. Redaelli, W. Scandale, "Installation of the LUA9 Equipment in IR7 of the LHC", Engineering Change Request, LHC-TEC-EC-0001, [EDMS 1329235](#).
- [3] S. Redaelli *et al.*, "Installation in IR7 of Primary Crystal Collimators (TCPC) on Beam 2", LHC-TC-EC-0008, [EDMS 1714148](#).
- [4] S. Redaelli *et al.*, "Replacement of one Primary Crystal Collimator (TCPC) in IR7", LHC-TC-EC-0010, [EDMS 1839549](#).
- [5] S. Redaelli, "Collimation Upgrade", presentation at the LHC Performance workshop, [Chamonix 2018](#) (2018). [PDF file](#) of the slides.
- [6] S. Redaelli, "Status and plans for crystal collimation", presentation at the [337th meeting of the LHC Machine Committee](#), LMC (2018). [PDF file](#) of the slides.
- [7] R. Bruce *et al.*, "Installation in IR7 of dispersion suppressor collimators (TCLD)", LHC-TC-EC-0013, EDMS 1973028, May 2018.